

**EPSON Stylus® Pro 4000**

PRINTER GUIDE

**EPSON®**

All rights reserved. No part of this publication may be reproduced, stored in a retrieval system, or transmitted in any form or by any means, electronic, mechanical, photocopying, recording, or otherwise, without the prior written permission of SEIKO EPSON CORPORATION. The information contained herein is designed only for use with these EPSON printers. EPSON is not responsible for any use of this information as applied to other printers.

#### **Trademarks**

EPSON, EPSON Stylus, EPSON ESC/P, and MicroWeave are registered trademarks of SEIKO EPSON CORPORATION.

Photo Enhance and EPSON UltraChrome are trademarks, and EPSON Preferred and EPSON Store are service marks, of Epson America, Inc.

*General Notice:* Other product names used herein are for identification purposes only and may be trademarks of their respective owners. EPSON disclaims any and all rights in those marks.

The ENERGY STAR emblem does not represent EPA endorsement of any product or service.

#### **Legal Notices**

Neither SEIKO EPSON CORPORATION nor its affiliates shall be liable to the purchaser of this product or third parties for damages, losses, costs, or expenses incurred by purchaser or third parties as a result of: accident, misuse, or abuse of this product or unauthorized modifications, repairs, or alterations to this product, or (excluding the U.S.) failure to strictly comply with SEIKO EPSON CORPORATION's operating and maintenance instructions.

SEIKO EPSON CORPORATION shall not be liable for any damages or problems arising from the use of any options or any consumable products other than those designated as Original EPSON Products or EPSON Approved Products by SEIKO EPSON CORPORATION.



Printed on recycled paper.

## FCC Compliance Statement

### For United States Users

This equipment has been tested and found to comply with the limits for a Class B digital device, pursuant to Part 15 of the FCC Rules. These limits are designed to provide reasonable protection against harmful interference in a residential installation. This equipment generates, uses, and can radiate radio frequency energy and, if not installed and used in accordance with the instructions, may cause harmful interference to radio or television reception. However, there is no guarantee that interference will not occur in a particular installation. If this equipment does cause interference to radio and television reception, which can be determined by turning the equipment off and on, the user is encouraged to try to correct the interference by one or more of the following measures:

- Reorient or relocate the receiving antenna.
- Increase the separation between the equipment and receiver.
- Connect the equipment into an outlet on a circuit different from that to which the receiver is connected.
- Consult the dealer or an experienced radio/TV technician for help.

## WARNING

The connection of a non-shielded equipment interface cable to this equipment will invalidate the FCC Certification of this device and may cause interference levels which exceed the limits established by the FCC for this equipment. It is the responsibility of the user to obtain and use a shielded equipment interface cable with this device. If this equipment has more than one interface connector, do not leave cables connected to unused interfaces. Changes or modifications not expressly approved by the manufacturer could void the user's authority to operate the equipment.

### For Canadian Users

This Class B digital apparatus complies with Canadian ICES-003.

*Cet appareil numérique de la classe B est conforme à la norme NMB-003 du Canada.*



# Contents

<b>Introduction</b>	9
Options and Accessories	10
Where To Get Help	11
Macintosh System Requirements	11
Windows System Requirements	12
ENERGY STAR Compliance	13
Important Safety Instructions	13
Ink Cartridge Safety Instructions	15
<b>1 Handling Paper and Other Media</b>	17
Selecting Media for Your Printer	17
Printing on EPSON Media	18
Guidelines for Using EPSON Media	19
Using Cut Sheet Paper	20
Using Roll Paper	26
Loading the Paper onto the Spindle	27
Placing the Paper in the Printer	27
Removing Paper from the Spindle	31
Switching Between 2-Inch and 3-Inch Roll Paper	31
Attaching the Spacer to the Spindle	32
Cutting Paper Manually with the Built-in Cutter	33
Printing Trim Lines	34
Loading Paper Manually	35
Loading a Sheet Manually in the Roll Paper Slot	38
Adjusting the Platen Gap for Thick or Thin Paper	39
Optimizing the Settings for Your Paper	40
Creating Paper Configurations	40
Selecting Paper Configurations	42

## 2 Printing with EPSON Drivers for Macintosh 43

Printing in Macintosh OS X .....	44
Choosing Page Setup Options .....	44
Choosing Basic Print Options .....	47
Choosing Color Management and Paper Configuration Options ..	50
Choosing Roll Paper Options .....	53
Creating a Custom Preset and Printing .....	54
Monitoring Print Jobs .....	55
Checking Ink Levels .....	56
Sharing Your Printer on a Network .....	57
Printing in Macintosh OS 9.x .....	58
Choosing Page Setup Options for Cut Sheet Printing .....	58
Choosing Page Setup Options for Roll Paper and Borderless Printing .....	59
Choosing Basic Print Options .....	62
Choosing Advanced Print Options .....	64
Managing Print Jobs .....	67
Monitoring Your Print Job .....	68
Checking Printer Status .....	69
Selecting Configuration Options .....	70
Sharing Your Printer on a Network .....	72

## 3 Printing with EPSON Drivers for Windows 73

Choosing Basic Print Options .....	74
Choosing Paper and Layout Options .....	76
Choosing Cut Sheet Paper Options .....	76
Choosing Roll Paper Options .....	78
Choosing Advanced Print Options .....	80
Managing Print Jobs .....	84
Using the Progress Meter .....	84
Setting Monitoring Preferences and Optimizing Print Speed .....	85
Sharing Your Printer on a Network .....	87

<b>4 Maintaining and Transporting the Printer</b>	<b>89</b>
Checking Printer Status and Part Life	90
Printing Status Information	90
Viewing Status Information	91
Checking and Cleaning the Print Head	92
Running a Power Cleaning Cycle	93
Aligning the Print Head	94
Replacing Ink Cartridges	96
Using the Maintenance Mode	100
Replacing the Paper Cutter Blade	101
Replacing the Maintenance Tank	104
Cleaning the Printer	106
Transporting or Storing the Printer	106
Preparing the Printer for Shipment	107
Setting Up the Printer After Transportation	108
Uninstalling and Reinstalling the Printer Driver	109
Macintosh OS X	109
Macintosh OS 9.x	110
Windows	110
<b>5 Solving Problems</b>	<b>111</b>
Diagnosing Problems	111
Checking Error Messages and Lights	112
Improving Print Quality	116
Solving Operational Problems	119
Solving Miscellaneous Printing Problems	121
Solving Paper Problems	122
Clearing Roll Paper Jams	123
Clearing Paper Tray Jams	125
Clearing Paper Jams from the Manual Feed Slots	127

<b>A Installing the Optional Print Server Card</b>	129
Removing the Print Server Card	130
<b>B Specifications</b>	131
Printing	131
Environmental	132
Electrical	132
Dimensions and Weight	132
Printer Interfaces	133
Safety Approvals	133
Media	133
Roll Paper	133
Cut Sheets	134
Printable Area	134
Ink Cartridges	135
<b>Index</b>	137

## Introduction

This *Printer Guide* provides important information on using your printer, selecting paper, and replacing ink cartridges. It also tells you how to maintain your printer to keep it working at its best, and provides troubleshooting tips in case you have a problem.

For additional information, see the following:

- The *Start Here* sheet shows how to set up your printer and install the software.
- The video CD-ROM, *Mastering Your Printer*, offers expert advice on printing from Adobe® Photoshop®, optimizing print quality, and performing basic operations.
- The *Quick Reference Guide* provides a handy summary of procedures for daily use and printer maintenance—loading paper, replacing ink cartridges and other components, checking and aligning the print head, and understanding error messages. Attach it to your printer for easy reference.
- The electronic *Reference Guide* on the CD-ROM provides additional information about the printer, drivers, and utility software. You can read the guide using a web browser, such as Netscape® Navigator® or Microsoft® Internet Explorer, versions 4.0 or later.

## Warnings, Cautions, Notes, and Tips

These symbols are used in this book:

**WARNINGS** must be followed carefully to avoid bodily injury.

**Cautions** must be observed to avoid damage to your equipment.

**Notes** contain important information about your printer.

**Tips** contain additional hints on how to get the most out of your printer.

**Tip:** Check the EPSON Pro Graphics web site at <http://prographics.epson.com> for new accessories and options that may become available.

## Options and Accessories

Your EPSON Stylus® Pro 4000 offers these optional upgrades and accessories:

### *Optional equipment and software*

Option	Part number
EPSON Stylus Pro 4000 Printer Cabinet Stand	C4000STAND
EPSON StylusRIP Professional 2.0 Software	C12C842972
Internal 10/100 BaseTX (Ethernet™) Type-B Print Server (interface card)*	C12C824052
Paper Roller Spindle (Normal Tension) — 2- or 3-inch	C12C811171
Paper Roller Spindle (High Tension) — 2- or 3-inch	C12C811191
One- and two-year extended warranties	EPP40EX1 (1-year) EPP40EX2 (2-year)

\* See Appendix A for details.

In addition, you can order these user-replaceable items:

### *Consumables and user-replaceable parts*

Part	Part number
Replacement Ink Maintenance Tank*	C12C890071
Replacement Printer Cutter Blade**	C12C815291
Ink Cartridges	See page 97 for a complete listing.
Paper (roll and sheet)	See page 18 for a complete listing.

\* See page 104 for details.

\*\* Replaces the blade for the printer's built-in cutter (see page 101).

You can purchase optional equipment and software, ink cartridges, paper, and manuals from EPSON® at (800) 873-7766, or you can visit the EPSON Store<sup>SM</sup> at [www.epsonstore.com](http://www.epsonstore.com) (U.S. sales only). In Canada, please call (800) 463-7766 for dealer referral.

Check the EPSON Pro Graphics web site at <http://prographics.epson.com> for new accessories and options that may become available.

## Where To Get Help

**Tip:** If you experience difficulty with the toll-free line or your Unit ID number, call (562) 276-1305.

EPSON provides technical support and information on the installation, configuration, and operation of professional printing products through the EPSON Preferred<sup>SM</sup> Protection Plan. Dial (888) 377-6611, 6 AM to 6 PM, Pacific Time, Monday through Friday. Support hours and days are subject to change without notice.

Before you call, make sure you have your Unit ID number, which is included with the EPSON Preferred Protection Plan information that came with your printer. You'll also need your printer serial number and proof of purchase.

EPSON also provides technical assistance 24 hours a day through the World Wide Web. You can reach EPSON Support at <http://support.epson.com>. At this site, you can download drivers and other files, look at product documentation, access troubleshooting information, and receive technical advice through e-mail.

You can purchase ink cartridges, paper, and accessories from EPSON at (800) 873-7766, or by visiting the EPSON Store at [www.epsonstore.com](http://www.epsonstore.com) (U.S. sales only). In Canada, please call (800) 463-7766 for dealer referral.

## Macintosh System Requirements

To use your printer in either a stand-alone or peer-to-peer network environment, your Macintosh<sup>®</sup> system should include the requirements listed below:

- OS 9.22 or OS X 10.2.8 or later
- 1.0 GHz or higher processor recommended
- At least 512MB of RAM
- At least 60MB of free hard disk space to install the software, and at least 2GB of free hard disk space for processing files (8GB or more available hard disk space recommended)
- Quad-speed (4×) or faster CD-ROM or DVD drive for installing the printer software

**Caution:** Using an improperly shielded cable—especially a cable more than 10 feet long—may cause the printer to malfunction.

- For USB connection: a compliant USB port and a shielded USB “AB” cable from Series A (computer) to Series B (printer), up to 10 feet long

For IEEE 1394 (FireWire®) connection: a shielded IEEE 1394 cable up to 10 feet long

For network connection: the optional Ethernet card (described on page 10) and a compatible cable

## Windows System Requirements

To use your printer in either a stand-alone or peer-to-peer network environment, your system should include the requirements listed below:

- IBM®-compatible PC with a Pentium® IV 1 GHz or higher processor recommended
- For USB connection: PC with USB port running Windows® 98 SE (factory installed), Me, 2000, or XP

For IEEE 1394 connection: PC with FireWire port running Windows Me, 2000, or XP

For 10/100 Base TX Ethernet connection: Ethernet equipped PC running Windows 98, Me, NT 4.0, 2000, or XP

- At least 512MB of RAM
- At least 100MB of free hard disk space to install the software, and at least 2GB of free hard disk space for processing files (8GB or more available hard disk space recommended)
- Quad-speed (4×) CD-ROM or DVD drive for installing the printer software
- For USB connection: a Windows-compliant USB port and a shielded USB “AB” cable from Series A (computer) to Series B (printer), up to 10 feet long

For IEEE 1394 (FireWire) connection: the optional IEEE 1394 port (described on page 10) and a shielded IEEE 1394 cable up to 10 feet long

For network connection: the optional Ethernet interface card (described on page 10) and a compatible cable



## ENERGY STAR Compliance

As an ENERGY STAR Partner, EPSON has determined that this product meets the ENERGY STAR guidelines for energy efficiency.

The EPA ENERGY STAR Office Equipment program is a voluntary partnership with the computer and office equipment industry to promote the introduction of energy-efficient personal computers, monitors, printers, fax machines, and copiers in an effort to reduce air pollution caused by power generation.

## Important Safety Instructions

Before using your printer, read the following safety instructions to make sure you use the equipment safely and effectively.

- The printer weighs about 88 lb (without ink or paper), and should be lifted by two people.
- When setting up the printer, make sure you have enough space around it, as shown below. You may need more space behind the printer if you print on large sheets of heavy stock or posterboard.

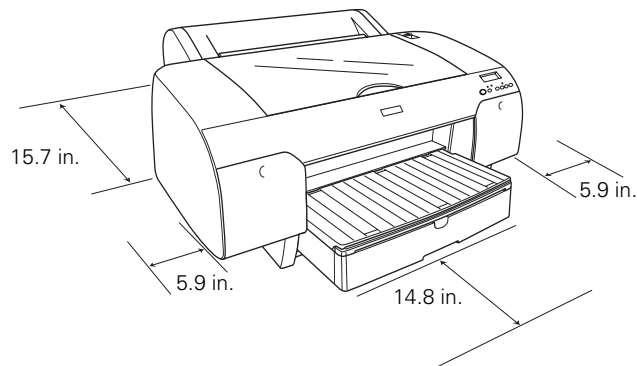

- Do not place the printer on an unstable surface or near a radiator or heating vent. Avoid areas subject to rapid changes in temperature and humidity or shock and vibrations.
- Do not place the printer near a window or in direct sunlight. Bright light can interfere with the paper sensors, causing paper jams and related problems.

- Do not store paper or other material on top of the printer. Doing so can interfere with the paper sensors.
- Keep the entire system away from potential sources of electromagnetic interference, such as loudspeakers or the base units of cordless telephones.
- Place the printer on a flat surface. It will not operate properly if it is tilted or at an angle.
- If you use a stand, make sure it can support at least 110.3 lb (50 kg)
- Do not block or cover the openings in the printer case or insert objects through the slots.
- Use only the type of power source indicated on the label.
- Connect all equipment to properly grounded power outlets. Avoid using outlets on the same circuit as photocopiers or air control systems that regularly switch on and off. Do not use outlets controlled by wall switches or timers.
- Place the printer near a wall outlet where the plugs can be easily unplugged.

*Placez l'imprimante près d'une prise de contacte où la fiche peut être débranchée facilement.*

**Caution:** Always turn the printer off using the  power button. When you press this button, **POWER OFF** appears on the LCD panel. Do not unplug the printer or turn off the power to the printer until the panel shuts off. This ensures that the print head is safely capped.

- Do not let the power cords become damaged or frayed.
- If you use an extension cord with the printer, make sure the total ampere rating of the devices plugged into the extension cord does not exceed the cord's ampere rating. Also, make sure the total ampere rating of all devices plugged into the wall outlet does not exceed the wall outlet's ampere rating.
- Turn off and unplug the printer before cleaning. Clean with a damp cloth only. Do not spill liquid on the printer.
- Except as specifically explained in the documentation, do not attempt to service the printer yourself. Opening or removing those covers that are marked "Do Not Remove" may expose you to dangerous voltage points or other risks. Refer all servicing in those compartments to service personnel.

- Power down the printer from the control panel, unplug the printer, and refer servicing to qualified service personnel under the following conditions:

If the power cord or plug is damaged; if liquid has entered the printer; if the equipment has been dropped or the case damaged; if the printer does not operate normally or exhibits a distinct change in performance.

Adjust only those controls that are covered by the operating instructions.

### **Ink Cartridge Safety Instructions**

- Do not put your hand inside the printer or touch the cartridges during printing.
- To avoid damaging the printer, do not move the print head by hand.
- Under normal circumstances, ink will not come out of the cartridge. If it does get on your skin, wash it off with soap and water. If it gets in your eyes, flush them immediately with water.
- Keep ink cartridges out of the reach of children and do not drink the ink.
- Do not store ink cartridges at high or freezing temperatures. Keep cartridges away from direct sunlight. Store cartridges in a cool, dark location.
- Do not dismantle the ink cartridges or try to refill them. This could result in damage to the print head.
- Do not touch the ink supply port or surrounding area, or the green IC chip on the side of the cartridge. This may affect normal operation and printing.



## Chapter 1: Handling Paper and Other Media

The EPSON Stylus Pro 4000 prints on a variety of media, including roll paper and cut sheets up to 17 inches wide. You can also use heavy stock, such as posterboard up to 59 mil (1.5 mm) thick, via the straight-through paper path.

This chapter includes the following information:

- Selecting media for your printer
- Printing on EPSON media
- Using cut sheet paper
- Using roll paper
- Loading paper manually
- Optimizing the settings for your paper

### Selecting Media for Your Printer

You can print on most types of coated, glossy, plain paper, and other media. An optional high-tension spindle is also available for printing on certain roll media such as EPSON UltraSmooth Fine Art Paper and Textured Fine Art Paper. The spindle applies tension to keep the paper tightly wound.

The following table shows the paper sizes you can use:

#### *Supported paper sizes*

	Roll paper	Cut sheets
Size	8 to 17 in. wide (203 to 432 mm)	8 × 10 in. up to 17 × 22 in.
Maximum external roll diameter	2 in. core: 4 in. (103 mm) 3 in. core: 6 in. (150 mm)	—
Thickness	3.15 to 19.7 mil (0.8 to 0.5 mm)	3.15 to 59 mil (0.8 to 1.5 mm)

Always test samples of paper stock in the printer before purchasing large quantities or printing large jobs. When you use non-EPSON paper or other media, you may need to adjust various settings and create special paper configurations. See page 40 for instructions.

**Note:** You can purchase additional roll paper spindles and other accessories or options from the EPSON Pro Graphics web site (<http://prographics.epson.com>) or your authorized EPSON dealer.

## Printing on EPSON Media

**Note:** Check the EPSON Pro Graphics web site (<http://prographics.epson.com>) or your authorized EPSON dealer for other media that may be available.

EPSON papers, which are specially designed for the inks used in the printer, ensure high-quality results. The following table lists the product codes for the EPSON media available for your printer.

### *EPSON media*

Paper type	Roll sizes and codes	Sheet sizes and codes
Photo Quality Ink Jet Paper	—	13" × 19": S041069 16.5" × 23.4": S041079 17" × 22": S041171
Premium Glossy Photo Paper (250)	16-inch roll: S041742	11" × 17": S041290 11.7" × 16.5": S041288 13" × 19": S041289
Premium Luster Photo Paper (250)	10-inch roll: S041644 16-inch roll: S041737	8.5" × 11": S041405 8.3" × 11.7": S041602 13" × 19": S041407, S041604
Premium Semigloss Photo Paper	—	8.5" × 11": S041331 13" × 19": S041327
Premium Semimatte Photo Paper (250)	16-inch roll: S041738	—
SingleWeight Matte Paper	17-inch roll: S041746	—
Enhanced Matte Paper	17-inch roll: S041725	8.5" × 11": S041341 8.3" × 11.7": S041603 11.7" × 16.5": S041343 13" × 19": S041744, S041339
EPSON Proofing Paper Commercial Semimatte	13-inch roll: S041668 17-inch roll: S041724	13" × 19": S041744
Watercolor Paper - Radiant White	—	13" × 19": S041351
EPSON Velvet Fine Art Paper	—	8.5" × 11": S041636 13" × 19": S041637

*EPSON media*

Paper type	Roll sizes and codes	Sheet sizes and codes
UltraSmooth Fine Art Paper*(250 gsm)	17-inch × 7': S041782-S 17-inch × 50': SP91205	17" × 22": SP91210 (325 gsm)
Textured Fine Art Paper*	17-inch roll: S041745	—
PremierArt™ Water Resistant Canvas for Epson**	13-inch roll: SP91220 17-inch × 10': SP91221-S 17-inch × 40': SP91221	—

\* Requires optional high-tension spindle.

\*\* Choose the **Watercolor Paper - Radiant White** Media Type setting for PremierArt Water Resistant Canvas for Epson.

## Guidelines for Using EPSON Media

Follow these guidelines, as well as those included in your paper package, when printing on EPSON paper and other media:

- Avoid touching the printable surface with your bare hands. Fingerprints may affect print quality. Handle media by the edges or use cotton gloves.
- Always choose the correct Media Type setting in your printer driver software before you send your job. See page 48 (Mac OS X), page 62 (Mac OS 9), or page 74 (Windows) for instructions.
- Always select the correct paper source (roll or sheet) in both the printer driver software and on the printer's control panel. See page 45 (Mac OS X), page 58 (Mac OS 9), or page 76 (Windows) for instructions on selecting the paper source in your printer software.
- Keep unused media in its original packaging and store it in a cool, dry place to maintain quality. Avoid storing your printouts where they will be exposed to high temperature, humidity, or direct sunlight.
- Store sheet media on a flat surface in its original package.
- The (250) designation and driver setting applies only to roll paper and 17" × 22" sheets.

## Using Cut Sheet Paper

You can print on many types of cut sheet paper and other media. The EPSON Stylus Pro 4000 accepts sheets ranging from 8 × 10 inches to 17 × 22 inches.

You can leave your roll paper on the spindle when you print on cut sheets; make sure it is removed from the paper path and rolled up.

If you're using fine art paper or other thick media, you need to load it manually, as described on page 35.

You can load up to 250 sheets of plain paper in the tray. The following table lists the paper tray capacity for various types and sizes of EPSON paper:

*EPSON cut sheet paper capacity*

Paper type	Size	Loading capacity
Photo Quality Ink Jet Paper	8.5" × 11"	200
	11.7" × 16.5" 13" × 19"	100
	17" × 22"	50
Premium Glossy Photo Paper	8.5" × 11"	100
	11.7" × 16.5" 13" × 19"	50
Premium Semigloss Photo Paper	8.5" × 11"	100
	13" × 19"	50
Premium Luster Photo Paper	8.5" × 11"	100
	11.7" × 16.5" 13" × 19"	50
Enhanced Matte Paper	8.5" × 11"	100
	11.7" × 16.5" 13" × 19"	50
Proofing Paper Commercial Semimatte	13" × 19"	50
Watercolor Paper - Radiant White	13" × 19"	20

Follow these steps to load cut sheets:

1. Make sure the printer is turned on, then press the < Paper Source button until the  sheet icon appears on the LCD display.
2. Extend the paper tray and paper tray cover.

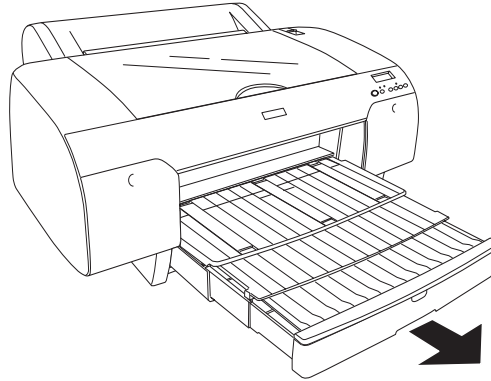

3. Lift up the paper tray cover.

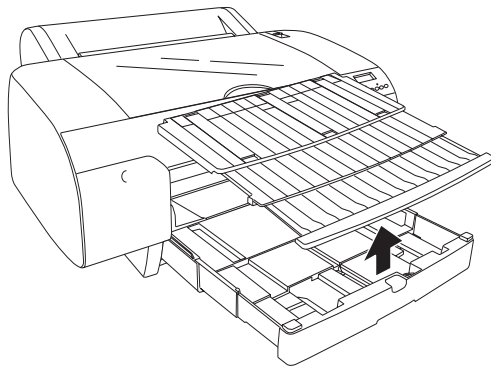

4. Flip up the paper guide roller and slide the edge guide all the way to the left.

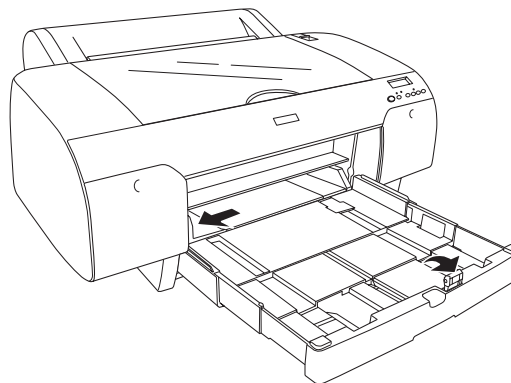

5. Clean the inside of the paper tray to remove any dust. Dust may affect printout quality.
6. Thumb through a stack of paper, then gently tap it on a flat surface to even the edges.

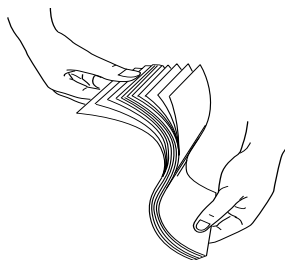

**Note:** When you add paper, always line up the edges with the remaining paper in the tray.

7. Load the sheets with the printable side down, in the portrait orientation (short edge first). Place the paper all the way back in the paper tray and next to the right edge.

Make sure the stack of paper fits under the arrow on the left edge guide.

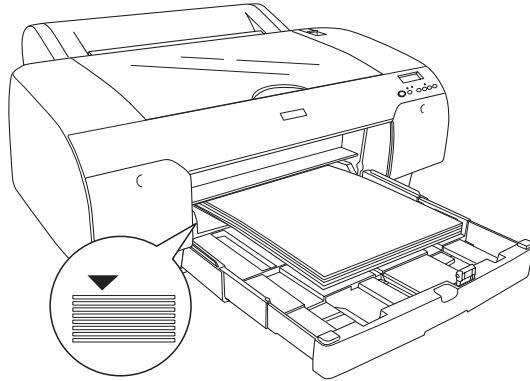

8. Adjust the edge guide and length of the paper tray.

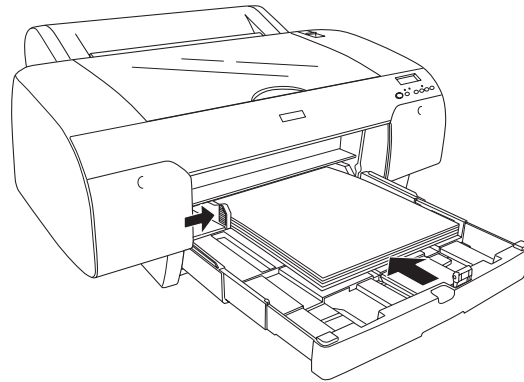

If you're printing on letter size paper, raise the paper guide and push it against the end of the paper stack.

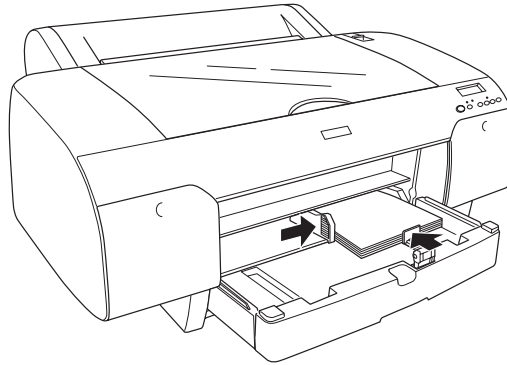

9. Flip the paper guide roller down onto the stack of paper.

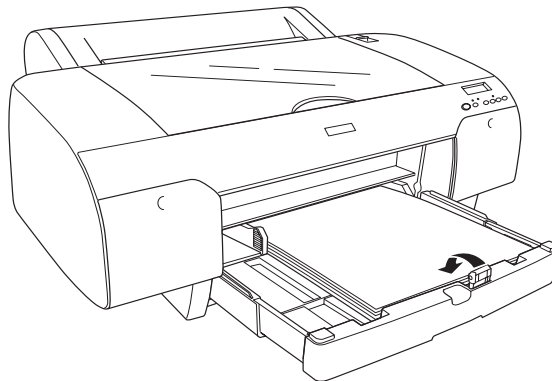

**Note:** Make sure the roll paper support on the paper tray cover is not raised.

10. Replace the paper tray cover and adjust its length.

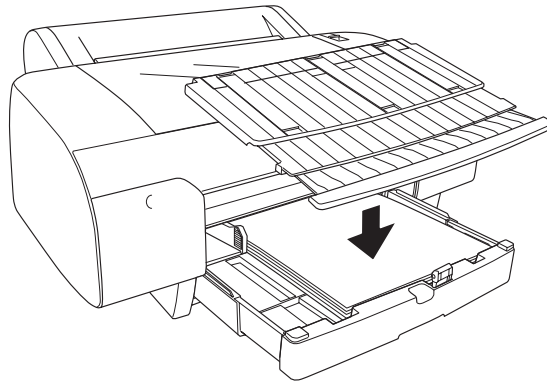



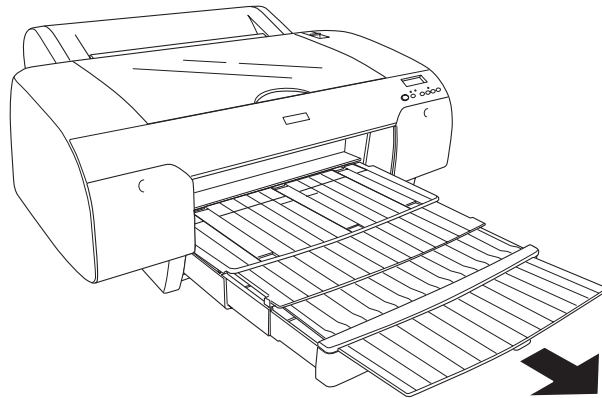



Extend the paper tray cover if necessary to support your printouts.



## Using Roll Paper

You can use any roll paper with a 2- or 3-inch core, up to 17 inches wide. Manually switching from one paper roll to another is a simple process.

When printing on roll paper, be sure to follow the media handling guidelines on page 19, as well as these special guidelines for roll paper:

- When storing roll paper, keep it in its original packaging—including the bag, end caps, and box.
- To avoid feeding excess paper, make sure the  Sheet icon does not appear on the LCD display. Press the < Paper Source button until the  or  roll icon appears on the LCD display.
- Choose  if you want the paper to be cut automatically after each page is printed.
- Choose  if you're printing on canvas or other heavy media. Media that is too thick will damage the cutter. Also choose this setting if you want to print a series of pages and keep them together for cutting later on. The following media (and other similar materials) do not work with the built-in cutter:
  - Fine Art Paper (including EPSON Textured, UltraSmooth, and Somerset® Velvet)
  - Canvas, including PremierArt Water Resistant Canvas for Epson
  - Vinyl
  - Matte board
  - Backlight film
  - Heavyweight polyester banner media
  - DuPont™ Semigloss Proofing Paper
- If you're loading heavy paper, you may need to increase the suction strength by pressing the paper feed  button. This helps hold the paper in place during loading and printing.

For lightweight paper, decrease the suction by pressing the  button.

**Note:** The spindle accommodates both 2-inch and 3-inch roll paper cores. To switch between different size cores, see page 31.

**Note:** Avoid touching the printable surface of the paper as much as possible. Oils from your skin can affect print quality.

## Loading the Paper onto the Spindle

Follow these steps to attach the roll to the spindle:

1. Slide the black paper stop (flange) off the left end of the spindle.

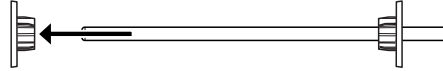

2. Position the roll so the paper unwinds as shown, then slide it onto the spindle:

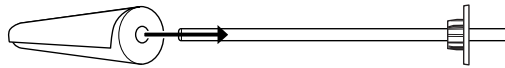

3. Slide the movable paper stop back onto the spindle and insert it into the end of the roll. Make sure it is firmly fixed into the left end of the paper roll.

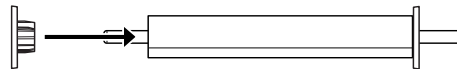

## Placing the Paper in the Printer

Follow these steps to place the paper in the printer:

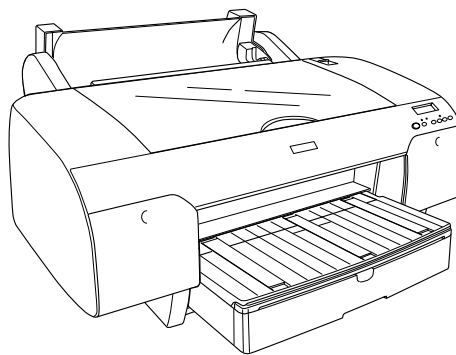

1. Open the roll paper cover.

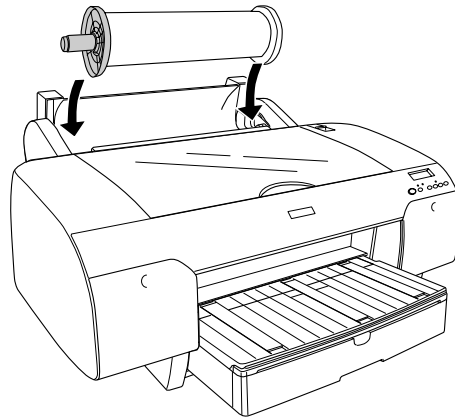

2. Place the roll paper in the printer as shown. (The white end of the spindle goes on the right.)



**Note:** To avoid feeding excess paper, make sure you don't select  when you're using roll paper.

3. Make sure the printer is turned on, then press the < Paper Source button until the  or  icon appears on the LCD display.
4. Release the paper lever.

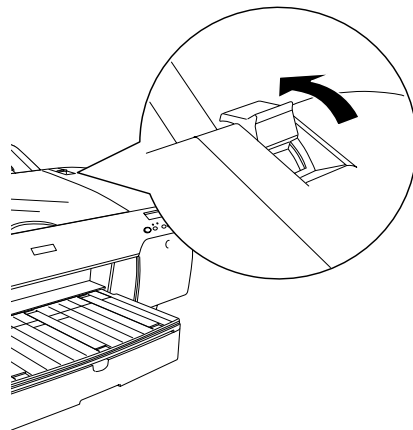

5. Hold both sides of the paper and feed into the slot.

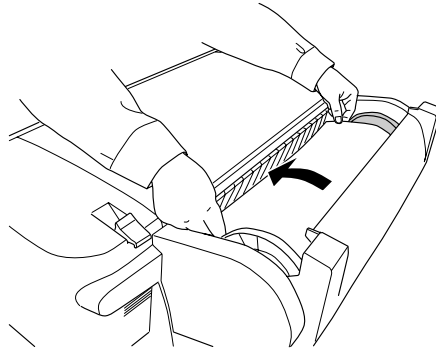

6. Feed the paper all the way through the printer until it is aligned with the A4/B4 mark on the paper tray cover.

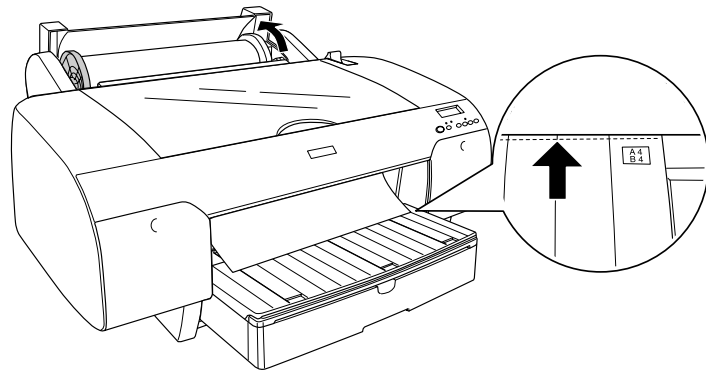

7. Move the paper lever to the secured position. The printer automatically positions the paper for printing.

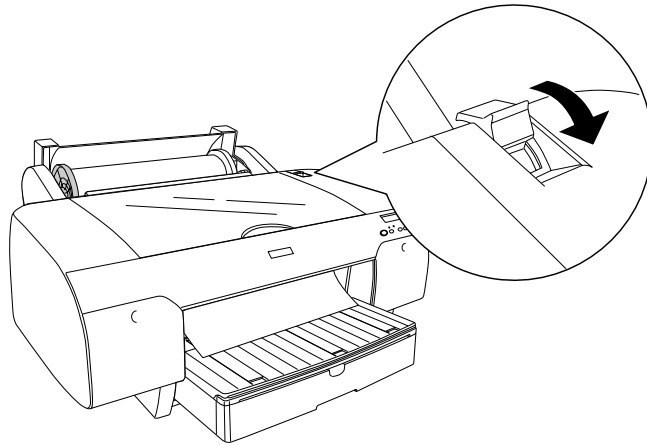

8. Raise the roll paper support.

**Note:** The maximum length of roll paper you can print on is not limited by the printer, but may be limited by your application software and/or operating system.

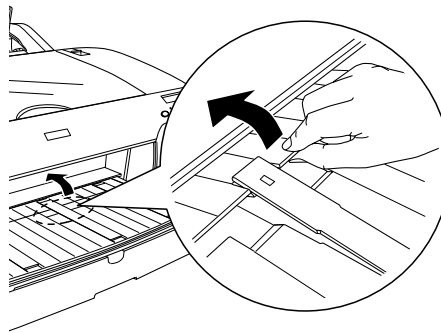

9. Close the roll paper cover.

To avoid indenting or creasing the paper, remove it from the paper path and roll it up when you are not printing.

## Removing Paper from the Spindle

If you need to remove the paper roll from the spindle, follow these steps:

1. Open the roll paper cover.
2. If the paper is loaded for printing, push the paper lever back to the released position, then roll up the paper before removing it.
3. Remove the roll paper and spindle from the printer.
4. Set the spindle upright, with the white end on the floor and the black end at the top.
5. Slide the black paper stop off the top of the spindle.
6. Remove the roll paper from the spindle.

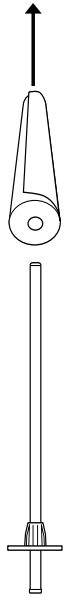

## Switching Between 2-Inch and 3-Inch Roll Paper

You can convert the spindle to accept roll paper with either a 2-inch or 3-inch core by using the spindle adapters. Follow these steps to attach the adapters for using 3-inch roll paper:

1. Remove the black paper stop from the end of the spindle.
2. Align the arrow marks as shown below and press one of the adapters onto the white paper stop until it locks in place. Press the other adapter onto the black paper stop.

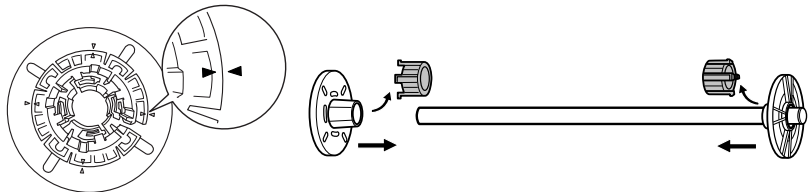

3. To remove the adapters, press toward the center on the four tabs shown below.

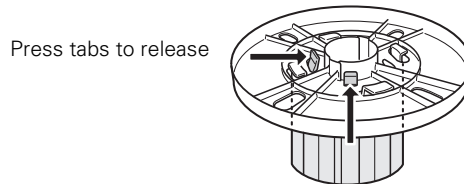

### Attaching the Spacer to the Spindle

If you want to create borderless prints on roll paper with a width of 8 inches (non-EPSON media), you need to use the spacer. You can only use the spacer when the adapters are removed from the spindle (2-inch core only).

1. Slide the black paper stop off the end of the spindle.
2. Slide the spacer onto the spindle.

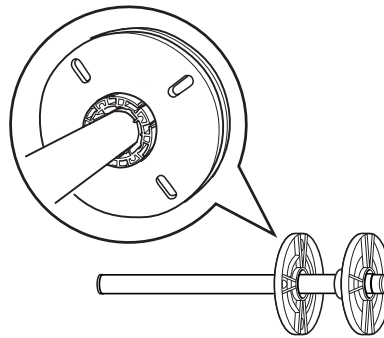

3. Slide the paper onto the spindle.
4. Slide the black paper stop back onto the spindle and insert it firmly into the end of the roll.

## Cutting Paper Manually with the Built-in Cutter

When you're not using the auto cut setting, you need to cut the paper manually by pressing the button after your print job is finished. You can use the button for most types of paper. However, if you're printing on fine art paper, canvas, or other heavy media, you should use scissors rather than the built-in cutter. See page 26 for a list of media that cannot be used with the built-in cutter.

Follow these steps to cut manually with the built-in cutter:



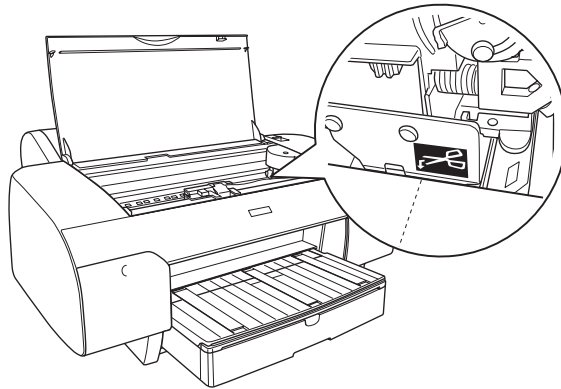

1. Before you print, press the < Paper Source button until you see the  icon.
2. Run your print job.
3. If the paper is not positioned correctly, press the  $\nabla$  or  $\blacktriangle$  button to match the cutting position on the paper with the cutting position on the left side of the print head.



4. Press the < button until you see the  auto cut icon on the LCD.
5. Press and hold the < button for 3 seconds. The paper is cut.

## Printing Trim Lines

You can print trim lines on the right edge of your pages (if you're using auto cut) or on the right and bottom edge (if you're not using auto cut). Follow these steps:

1. Press the **Menu**  button. **Printer Setup** appears on the display.
2. Press the **Menu**  button again to select the **Printer Setup** menu and display **PLATEN GAP**.
3. Press the **▼** button to display **PAGE LINE**.
4. Press the **Menu**  button. **OFF** is displayed as the current setting.
5. Press the **▼** button so that **ON** appears.
6. Press the **Menu**  button to save the setting. An asterisk appears next to **ON**.
7. Press the **■** **Pause** button to exit the menu.

You can also specify trim lines from your printer driver software. For instructions, see page 54 (Mac OS X), page 61 (Mac OS 9), or page 80 (Windows).

## Loading Paper Manually

If you want to print on fine art paper, posterboard, or other media 19 to 59 mil (0.5 to 1.5 mm) thick, you need to use the manual feed slot. This provides a straight-through paper path. Be sure to allow enough room behind the printer so the paper is not bent when it feeds into printing position.

1. Make sure the printer is turned on, then press the < Paper Source button until the  sheet icon appears on the LCD display.
2. Release the paper lever.

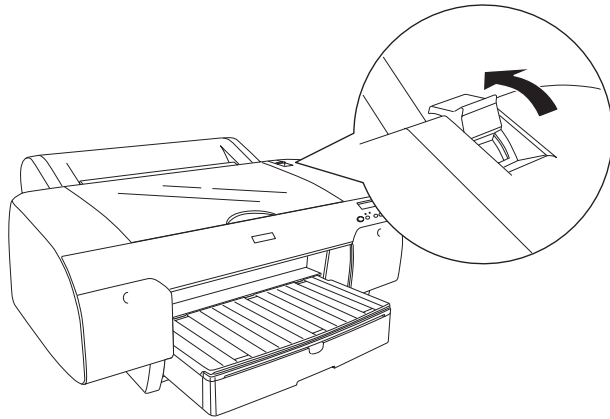

3. Open the top cover.

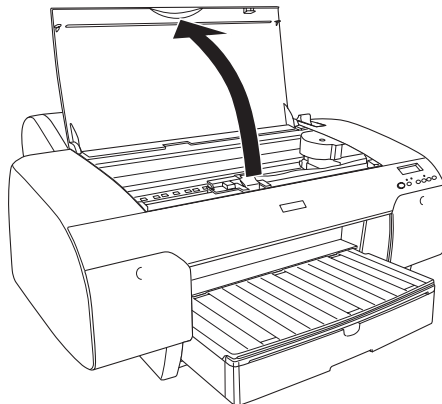

4. Insert the sheet face-up over the black rollers.

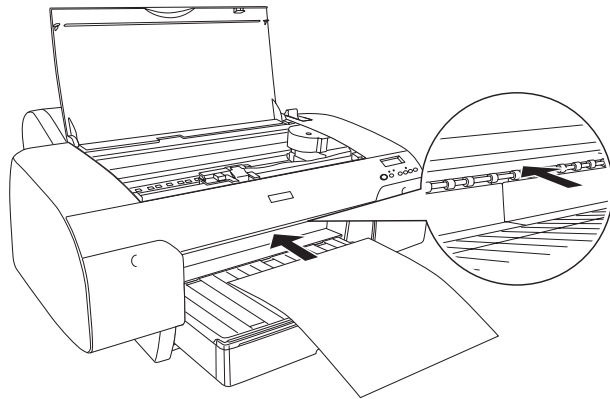

5. Push the sheet under the feed roller and over the black rollers, with the right edge against the right edge of the feed slot.

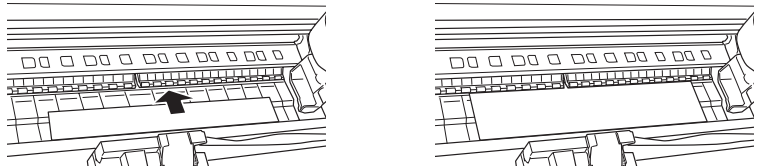

6. Align the edges with the marks on the paper tray cover. Then close the top cover.

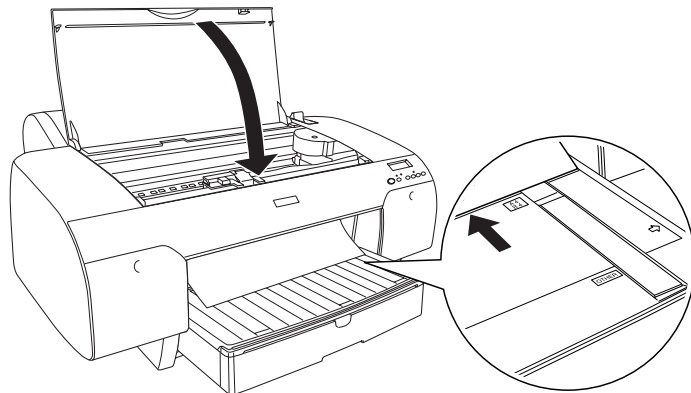

7. Return the paper lever to the secured position. The printer automatically feeds the paper into printing position.

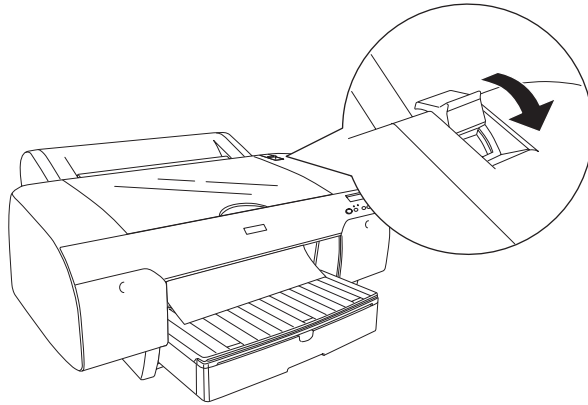

8. Extend the paper tray and cover to support the sheet as it comes out of the printer. Make sure the roll paper support is not raised.

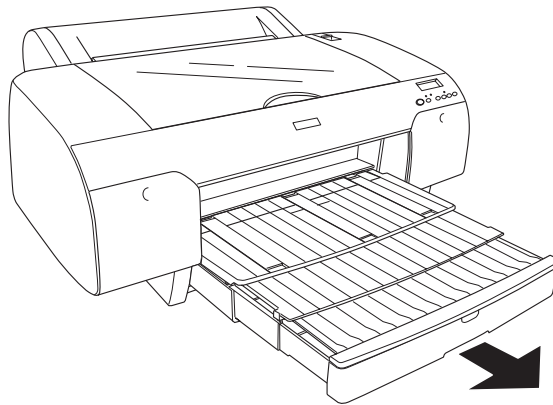

## Loading a Sheet Manually in the Roll Paper Slot

If you want to print on a single sheet of paper, you don't have to load it into the paper tray. You can insert it in the roll paper slot, following these steps:

1. Make sure the printer is turned on, then press the < Paper Source button until the  sheet icon appears on the LCD display.
2. Align the sheet with the right edge of the slot and insert it until it meets resistance.

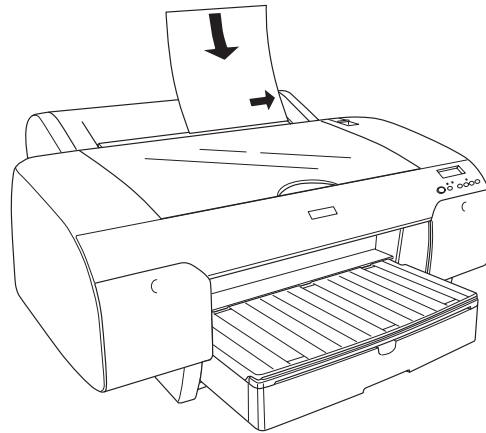

The printer automatically feeds the sheet into printing position.

3. Extend the paper tray and cover to support the sheet as it comes out of the printer. Make sure the roll paper support is not raised.

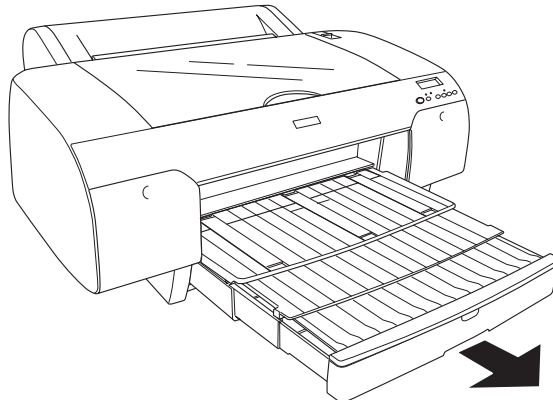

## Adjusting the Platen Gap for Thick or Thin Paper

**Caution:** To avoid damaging the printer, make sure you do not select the **Narrow** setting when you print on heavy media.

When you print on unusually thick or thin paper, you may need to adjust the platen gap setting. Normally, the **STANDARD** setting allows the printer to adjust automatically. However, if print quality is not satisfactory when using very thin or very thick stock, you may need to change this setting. Follow these steps:

1. Press the **Menu** > button. **Printer Setup** appears on the display.
2. Press the **Menu** > button again to select the **Printer Setup** menu and display **PLATEN GAP**.
3. Press the **Menu** > button. **STANDARD** is displayed as the current setting.
4. Use the **▼** and **▲** buttons to change the setting. (**STANDARD** is the default setting; you can also choose **NARROW**, **WIDE**, or **WIDER**.)
5. Press the **Menu** > button to save the setting. An asterisk appears next to the selected setting.
6. Press the **||** **Pause** button to exit the menu.

If you've selected a non-standard platen gap, the letter **N** or **W** appears in the corner of the display to remind you of the narrow or wide setting. When you switch media, don't forget to change the setting back to **STANDARD**.

If you're printing on non-EPSON media, you may also need to create a paper configuration to optimize your results. See the following section for more information.

## Optimizing the Settings for Your Paper









When you choose a media type in your EPSON printer software, the driver automatically determines the best settings for your paper. However, you may want to fine-tune how the printer handles various media—especially if you use non-EPSON paper or a paper not supported by the driver. Use the paper configuration settings described below. If you're printing on unusually thick or thin paper, you may also need to adjust the platen gap; if so, you should do that first (see page 39).

**Note:** It's a good idea to keep a list describing your paper configurations.

You can create a special configuration, or group of settings, for each paper type (up to ten types) and select the desired configuration whenever you print on a particular stock.

## Creating Paper Configurations

To create a configuration for a specific paper type, make sure the paper you want to configure is loaded in the printer. Then follow these steps:

1. Press the Menu  button, then press the  button until CUSTOM PAPER appears on the display.
2. Press the Menu  button to display PAPER NUMBER.
3. Press the Menu  button, then press the  button to select a paper configuration number (1 to 10).
4. Press the Menu  button to display PLATEN GAP. Press the  button to select NARROW, STANDARD, WIDER, or WIDE.
5. Press the Menu  button to save the selected platen gap setting and display THICKNESS PAT.
6. Press the Menu  button again to print the paper thickness pattern. The printer prints a pattern similar to the following:

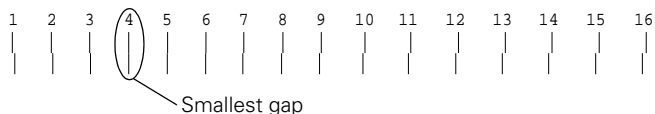

7. Examine the printed pattern for the most evenly overlapping lines. In the example shown above, the lines under number 4 are the most even.
8. After printing the pattern, **THICKNESS NUM** is displayed. Press the **✓** button to select the number noted in step 7.
9. Press the **Menu**  button to save the selected value.

The menu options shown below appear in sequence. Make any adjustments, as needed, and press the **Menu**  button to save each setting.

You can also make similar settings using the printer driver software. For instructions, see page 50 (Mac OS X), page 66 (Mac OS 9), or page 83 (Windows).

- **CUT METHOD** lets you decrease the cutting blade pressure for thinner media, or adjust the speed for thick media. You may need to experiment to determine the cleanest cut for your paper.
  - **PPR FEED ADJUSTMENT** helps eliminate banding. Choose a lower value if you see white lines on your prints, or a higher value if you see dark lines.
  - **EJECT ROLLER TYPE** lets you define the eject roller for printing with non-EPSON media. You may need to experiment to determine the best setting for your paper.
  - **DRYING TIME** lets you print with non-EPSON media and avoid smearing the ink. You can make the print head wait up to 5 seconds after each pass to allow ink to dry on the page.
  - **SUCTION** lets you decrease the paper suction level when printing on thinner media (less than 12 lb), such as CAD drafting paper or backlight film.
  - **M/W ADJ** adjusts the intensity of the MicroWeave® pattern. This improves print quality, but lowers printing speed.
10. When done, press the **■** Pause button.

## Selecting Paper Configurations

Once you have created a paper configuration, you can select it whenever you print on that paper:

1. Press the **Menu** >/< button, then press the **▼** button to display **CUSTOM PAPER**. Press the **Menu** >/< button again.
2. Press the **▼** button to display **PAPER NUMBER**, then press the **Menu** >/< button.
3. Press the **▼** button to select the configuration number that you want to use.

If you select **STANDARD**, the printer uses the driver settings. If you select a number from 1 to 10, the control panel settings override the driver settings.

4. Press the **Menu** >/< button. The configuration number you selected is displayed on the LCD.
5. Press the **■** Pause button to exit the menu.

## Chapter 2: Printing with EPSON Drivers for Macintosh

Your EPSON Stylus Pro 4000 comes with drivers and utilities that let you print and manage print jobs in non-PostScript® mode. ICC profiles for ColorSync® are included, so you can use color management features in Photoshop or other applications, or in the driver itself.

A color-managed workflow using Adobe Photoshop will give you the most accurate colors and best photographic output from your EPSON Stylus Pro 4000. You need to make sure your Photoshop color settings are optimized for your printer, as described on the *Mastering Your Printer* CD-ROM.

You can create your own profiles if you have the required hardware and software, or you can have them created by a service bureau. Make sure any profiles you want to use are located in the standard folder for your operating system. When you install the EPSON printer driver, the ready-made profiles are automatically copied to the right folder.

**Tip:** Check the EPSON Pro Graphics website at <http://prographics.epson.com> for updated drivers and utilities that may become available.

This chapter includes the following information for both Macintosh OS X and OS 9.x:

- Choosing page setup settings for cut sheets and roll paper
- Choosing basic print settings
- Choosing advanced print options, including color management and paper configuration settings
- Monitoring print jobs
- Checking printer status
- Sharing your printer on a network

## Printing in Macintosh OS X

Before you print, make sure you have installed the EPSON printer driver and utilities from the CD-ROM. You also need to configure your connection and select the various media input types that you want to use. For instructions on installing and configuring the printer driver, see the *Start Here* sheet.

**Note:** Many application settings override the printer's page setup options. Always verify settings to get the results you expect.

If you need more information about print options, click the **Help** button.

### Choosing Page Setup Options

Page Setup options let you choose from several media input types for printing on cut sheets or roll paper. You can also select the orientation of your image and the paper size. For printing on roll media, you can create a custom page size to make the best use of your paper.

1. Open the file you want to print and select **Page Setup** in your application. You see this screen:

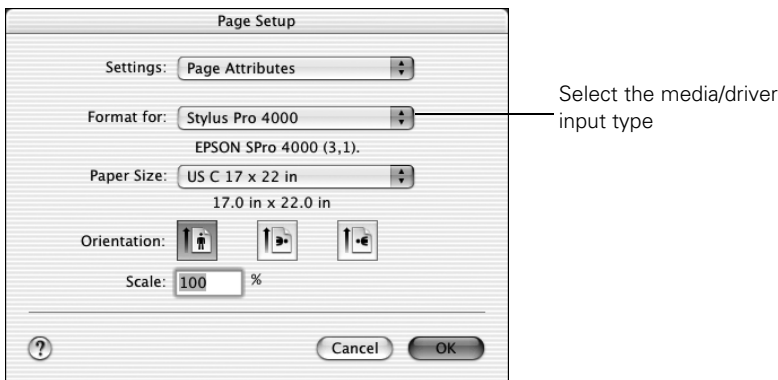

2. Open the **Format for** pull-down menu and select the media input type you want to use.

The available settings depend on which media input types you selected in the Print Center, including both standard and borderless printing.

Note the following limitations on borderless printing:

- Borderless printing takes longer than normal printing.
- Margins are required at the top and bottom of the page on cut sheets. Full borderless printing is available on roll paper only.

**Note:** If your application has margin settings, make sure they're turned off for borderless printing.

3. Choose one of the following:
  - **Stylus Pro 4000** (the standard setting) prints on cut sheet paper with a bottom margin larger than the top and sides.
  - **Borderless (Auto Expand)** prints on cut sheets and enlarges your image (up to 3%) to fit the width of the paper (without side borders).
  - **Borderless (Retain Size)** prints your image at the size you specify in your application. You need to size it about 1/4 inch wider than the paper width to print without side borders.
  - **Maximum** reduces the bottom margin (available for printing on plain paper sheets only).
  - **Roll Paper - Banner** prints a series of continuous images without any margin space between them, but with normal side borders.
  - **Roll Paper - Borderless (Auto Expand)** prints without borders on roll paper and enlarges your image (up to 3%) to fit the size of the paper.
  - **Roll Paper - Borderless (Retain Size)** prints your image on roll paper at the size you specify in your application. You need to size it about 1/4 inch wider than the paper width to print without borders.
  - **Roll Paper - Borderless Banner** prints a series of continuous borderless images without space between them.
  - **Roll Paper** prints on roll paper with the standard printable area.
4. Click the **Paper Size** pull-down menu.
  - If you're printing on cut-sheets, select the size of the paper loaded in the printer. Then continue with step 7.
  - If you're using roll paper, you can select the size of your image as the paper size.

Or, to make the best use of your paper, you can create a custom page size. Click the **Settings** pull-down menu (at the top of the screen) and select **Custom Paper Size**.

You see this screen:

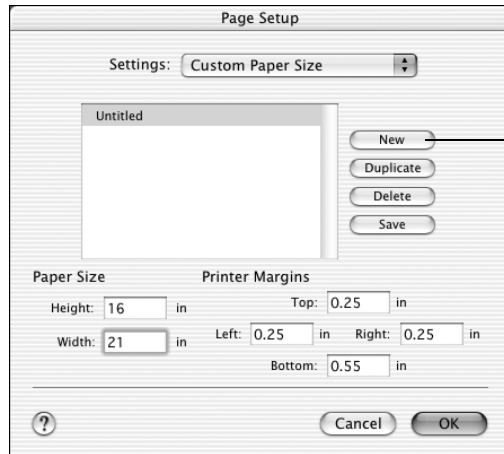

Click New to define your custom paper size

**Tip:** To ensure that the image is centered on the page, make the top and bottom margins the same.

5. Click **New**, double-click **Untitled**, give your paper size a name, and define its size and margins. Then click **Save**.
6. Select your new page size.
7. When done, select **Page Attributes** from the Settings pull-down menu.
8. Choose the **Orientation** and **Scale** for printing.
9. Click **OK**. Then continue with the instructions in the next section to select additional settings for printing.

## Choosing Basic Print Options

Once you have selected your page setup options, you need to select printing options. The EPSON driver offers automatic settings that optimize print quality and speed when you're using EPSON media. You can also choose advanced settings for more control over your printer and color management options, as described on page 50.

1. Select **Print** in your application. You see the screen shown below:

**Caution:** Always select the same setting for the **Printer** option in the Print window and the **Format for** option in the Page Setup window. If the settings are different, you may get unexpected results.

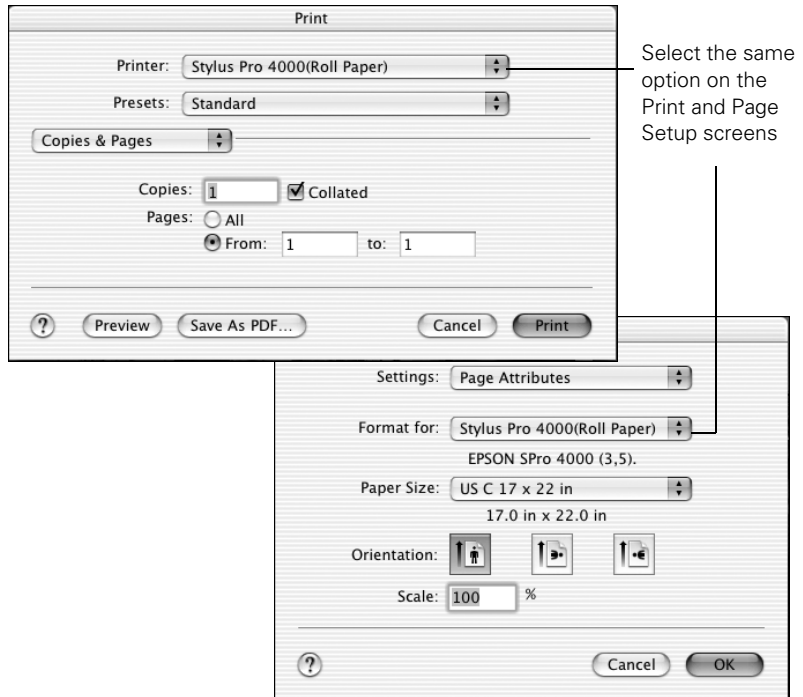

2. Open the **Printer** pull-down menu and select the same media input type for your printer that you chose in the Page Setup window.
3. Select **Print Settings** from the pull-down menu.

You see this screen:

Select the Print Settings page

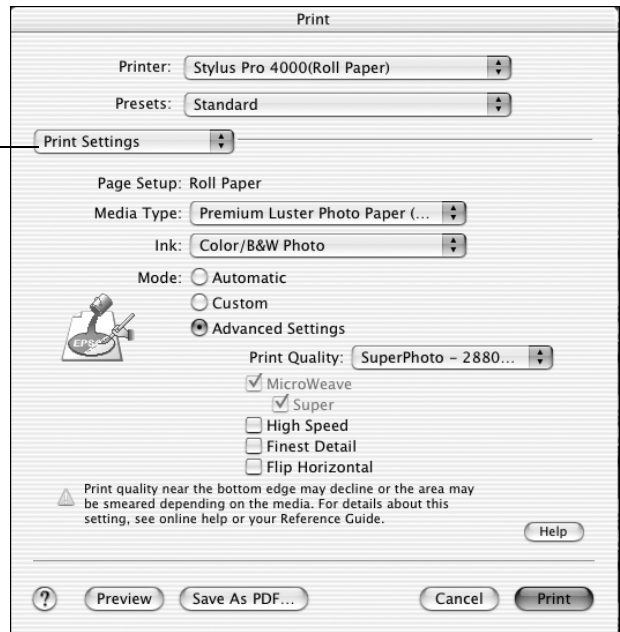

4. Select the **Media Type** that corresponds to the paper you are printing on. If you are using a color-managed workflow, make sure you choose media type and resolution settings that match the ICC profile you are using.

**Note:** Check the web site (<http://prographics.epson.com>) or your authorized EPSON dealer for other media that may be available.

The settings followed by (250) are for roll paper or 17-inch wide sheets. Choose a setting without the (250) designation when you print on smaller sheets. For PremierArt Water Resistant Canvas for Epson, choose the **Watercolor Paper - Radiant White** setting.

If your paper is not listed, check the instructions included with the paper, or look on the EPSON web site (<http://prographics.epson.com>). If you are using non-EPSON paper, choose the closest setting. You may have to experiment with different settings to determine which one is best for the media you're using.

5. For the Ink setting, select **Color/B&W Photo** for any type of photographic printing. Select **Black** only if you're printing line drawings or other non-photographic images.

6. Set the **Mode** option as follows:

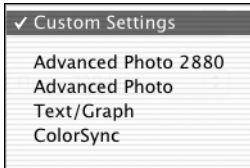

- Click **Automatic** to have the printer driver analyze the contents of your image or file and make the appropriate printing adjustments. If a **Quality/Speed** slider appears in the Mode box, set it according to the priorities of your print job.
- Click **Custom** and then choose one of the settings shown at the left.

The two **Advanced Photo** settings let you print at either 1440 dpi (**Advanced Photo**) or 2880 dpi, the highest resolutions available.

The **Text/Graph** setting intensifies colors and lightens the midtones and highlights for non-photographic output.

The **ColorSync** setting applies color management based on the printer's ICC profile, using the perceptual rendering intent. In most cases, you will get better results by applying color management in your application, rather than in the printer driver.

- Click **Advanced Settings** to access additional options, as described below.

7. Choose one of the following **Print Quality** settings:

- **Draft** to save ink
- **Normal - 360dpi** for faster printing and everyday needs
- **Fine - 720dpi** for photo lab quality photos and prints
- **SuperFine - 1440dpi** for better than photo lab quality
- **SuperPhoto - 2880dpi** for the highest quality photos and prints; provides an astonishing level of photographic quality

8. Choose any of the following:

- **High Speed** for fast, bidirectional printing. For higher quality, make sure you deselect this option.
- **Finest Detail** for sharper edges on text, graphics, and line art.
- **Flip Horizontal** for printing a mirror image of your file. Use with backlight film.

**Note:** The Print Quality settings available depend on the Media Type you selected. Choose lower print quality for faster printing, or SuperPhoto - 2880dpi for best quality.

Continue with the instructions in the next section to select color management settings. If you are using the color management settings in Photoshop or another application, it is very important to turn off color management in the printer driver, as described page 51.

## Choosing Color Management and Paper Configuration Options

Follow these instructions to turn off color management in the printer driver. If necessary, you can control the ink density by using the paper configuration settings, as described on page 51.

1. Select **Printer Color Management** from the pull-down menu. You see this screen:

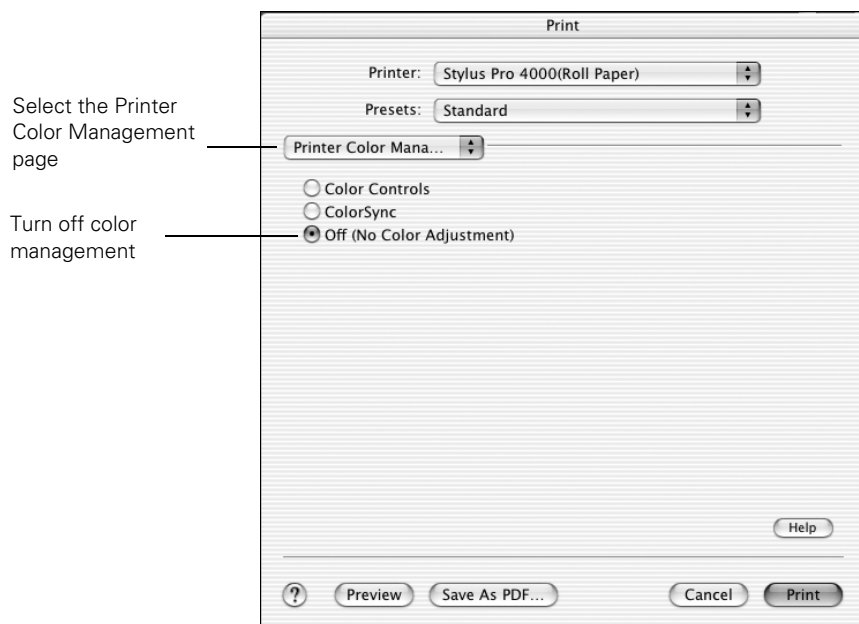

2. Select one of the following settings:
  - **Color Controls** to specify individual values for brightness, contrast, saturation, and CMY inks, or choose from three Color Adjustment modes. You can also choose from three Gamma settings.

- **Color Sync** to select from three Rendering Intent settings for mapping colors to your printer’s profile. In most cases, you will get better results by applying color management in your application, rather than in the printer driver.
- **No Color Adjustment** to disable color management in the printer driver. Choose this mode when you use a color-managed workflow in Photoshop or other software applications.

**Note:** Be sure to check the Color Density setting. You may need to change it if your color profile was created to optimize D-max and color gamut.

3. If you are using non-EPSON media and you need to fine-tune its performance, select **Paper Configuration** from the pull-down menu. You see this screen:

Select the Paper Configuration page

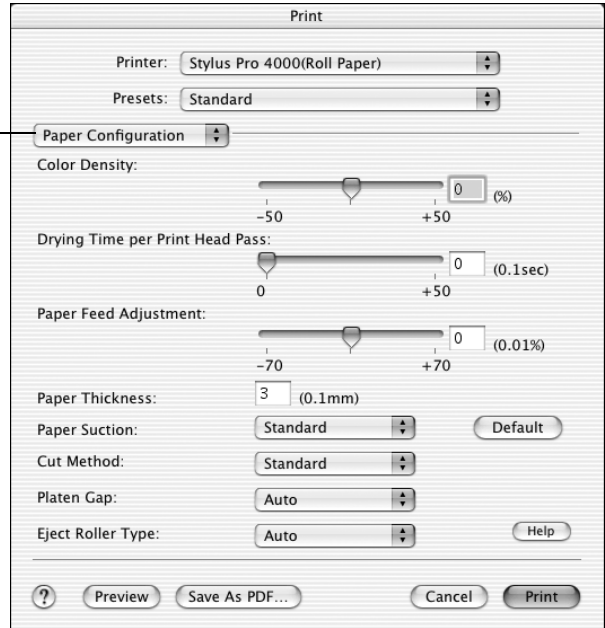

4. Select the correct settings to match your ICC profile. These settings override any paper configuration settings you may have made using the printer’s control panel.
  - **Color Density** lets you control the ink saturation level (for example, when you turn off color management in your printer software).

- **Drying Time per Print Head Pass** lets you print with non-EPSON media and avoid smearing the ink. You can make the print head wait up to 5 seconds after each pass to allow ink to dry on the page.
- **Paper Feed Adjustment** helps eliminate banding. Choose a lower value if you see white lines on your prints, or a higher value if you see dark lines.
- **Paper Suction** lets you decrease the paper suction level when printing on thinner papers (less than 12 lb), such as CAD drafting paper or backlight film.
- **Paper Thickness** eliminates vertical banding and creates a sharper image when printing on unusually thick or thin paper.
- **Cut Method** decreases the cutting blade pressure for thinner media, or adjusts the speed for thick media. You may need to experiment to determine the best setting for your paper.
- **Platen Gap** lets you fine-tune the setting for various paper thicknesses.
- **Eject Roller Type** lets you define the eject roller for printing on non-EPSON media. You may need to experiment to determine the best setting for your paper.

## Choosing Roll Paper Options

If you are printing on roll paper, you need to check these settings for various cutting options.

1. Select **Roll Paper Option** from the pull-down menu shown below. You see this screen:

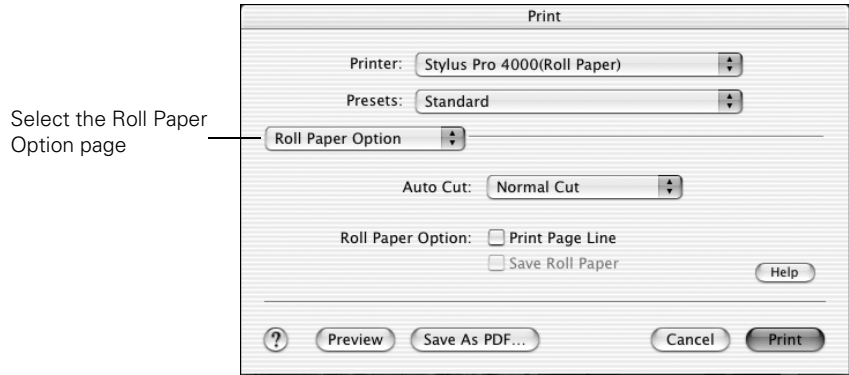

2. Choose one of the following **Auto Cut** settings:
  - **Normal Cut** allows margin space at the top and bottom of each image.
  - **Double Cut** extends the space between the images and trims each print individually. This provides the cleanest edge for borderless printing.
  - **Single Cut** causes the images to be printed end-to-end and saves paper. With borderless printing, you may see a sliver of the previous or next image.
  - **Off** disables automatic cutting. Choose this setting if you want to operate the cutter manually, print multiple print jobs without cutting, or if you are printing on heavy media that must be cut with scissors.

See page 33 for instructions on using the button to operate the cutter. See page 26 for a list of media that do not work with the built-in cutter.

**Note:** These settings override settings made through the control panel.

**Note:** If you check the settings on each screen in the pull-down menu, go through them carefully from top to bottom. Avoid cycling through them repeatedly, or you may lose your settings.

3. Select either of the following options:
  - **Print Page Line** prints trim lines on the right and bottom edges of your pages.
  - **Save Roll Paper** saves paper by not feeding the blank portion of the last page of your document. Available only when you've selected **Roll Paper (Banner)** as the Paper Source.

## Creating a Custom Preset and Printing

Once you've made the correct settings for your print job, create a custom preset. This will save you time when you use the same profile/printer/ink/media combination for future print jobs.

1. Select **Summary** from the pull-down menu.
2. After verifying that your settings are correct, select **Save As** from the Presets pull-down menu.

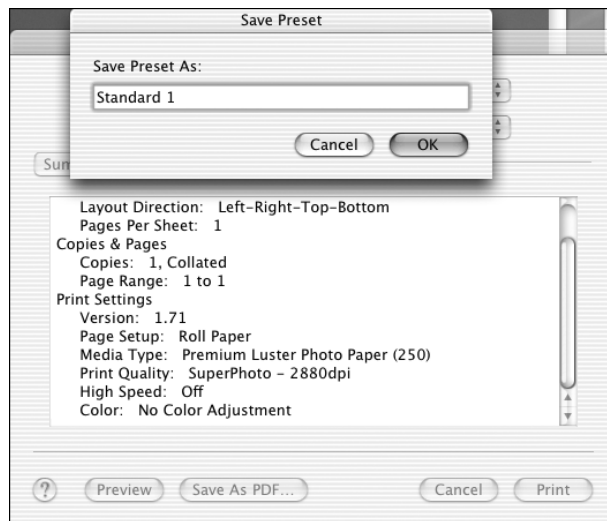

**Caution:** Do not open and close the Presets pull-down menu without typing a name, or you will lose your settings.

3. Type a name, and click **OK**.
4. When you're ready to print, click the **Print** button. The Print Center icon appears in the dock on the bottom of your desktop.

See the next section for instructions on monitoring your print job.

## Monitoring Print Jobs

After you click **Print**, you can monitor the progress of your print job using the Print Center. Follow these steps:

1. Click the **Print Center** icon when it appears in the dock on the bottom of your desktop.
2. Double-click your printer (and media input) name. You see a screen like this:

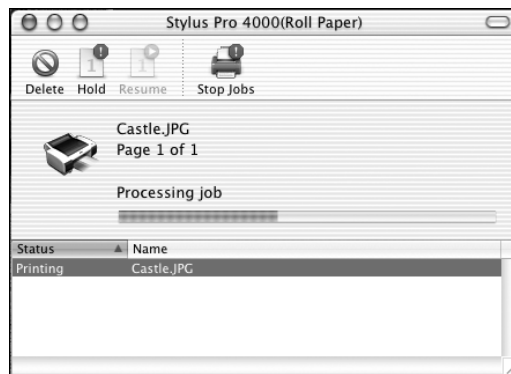

3. From here you can monitor the progress of your print job or do one of the following:
  - Click the print job, then click **Delete** to cancel the job
  - Click the print job, then click **Hold** to pause printing
  - Click a print job marked “Hold” and click **Resume** to resume printing
  - If Multiple print jobs are listed, click a print job, then click the **Priority** arrow as necessary to reorder the jobs
4. When you’re finished, close the print job window, then close Print Center.

## Checking Ink Levels

The EPSON Printer Utility lets you check the levels of ink in the printer. You can also run maintenance utilities from this screen. See pages 92 to 93 for instructions.

1. Double-click the **Applications** folder on your hard drive.
2. Double-click **EPSON Printer Utility**.
3. Select your printer and click **OK**. You see the EPSON Printer Utility screen:

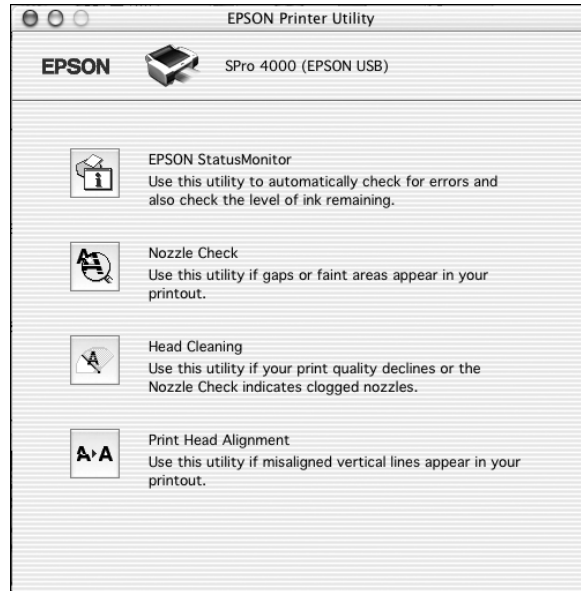

4. Double-click the **EPSON StatusMonitor** icon.

The software checks the amount of ink remaining in the printer and displays the StatusMonitor window:

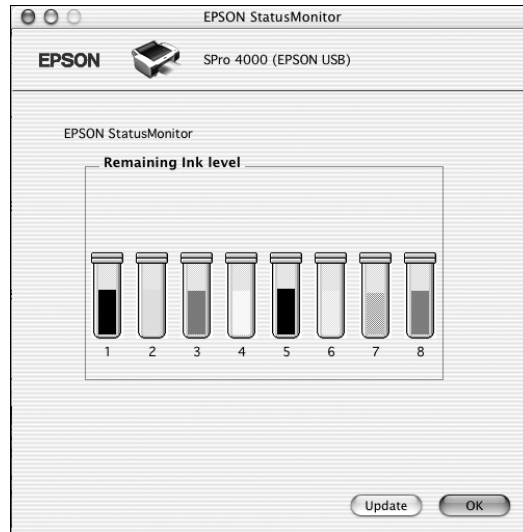

5. To recheck the ink level, click the **Update** button. To close the Status Monitor, click **OK**.

## Sharing Your Printer on a Network

If the printer is connected to a Macintosh on a network, other computers on the network can also access the printer.

1. On the Macintosh to which the printer is connected, open **System Preferences > Sharing**.
2. Click the **Printer Sharing** checkbox, then click the **Start** button. This turns on printer sharing.
3. On other Macintosh computers on the network, open **Print Center**, then open the **Preferences** menu.
4. Select **Show printers connected to other computers**. Shared printers are highlighted on the Printer List screen.

## Printing in Macintosh OS 9.x

Before you print, make sure you have installed the EPSON printer driver and utilities from the CD-ROM. You also need to select your printer in the Chooser. For instructions on installing and selecting the printer driver, see the *Start Here* sheet.

**Note:** Many application settings override the printer's page setup options. Always verify settings to get the results you expect.

If you need more information about print options, click the ? button on any dialog box.

### Choosing Page Setup Options for Cut Sheet Printing

Many of the page setup options correspond to paper handling features that you can also set through the control panel. Software options give you additional settings and override control panel settings.

1. Open the file you want to print, and select **Page Setup** in your application. You see the page setup dialog box:

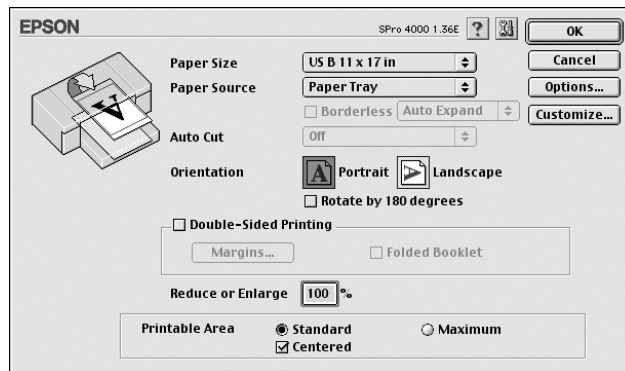

2. If you're using cut sheets, select the **Paper Size**.

If you're using roll paper, you can select the size of your image for the Paper Size. For more information about printing on roll paper, see page 59.

3. Select **Paper Tray**, **Manual Feed**, or one of the Roll Paper sizes from the **Paper Source** list. For more information about printing on roll paper, see page 59.
4. Make the settings you want for **Orientation** and **Reduce or Enlarge**.

5. If you want to print on both sides of the paper, select **Double-Sided Printing**. See your electronic *Reference Guide* for more information about double-sided printing.
6. Choose one of the following for **Printable Area** (available only when **Paper Source** is set to **Paper Tray**):
  - **Standard** makes the bottom margin larger than the top and sides.
  - **Maximum** reduces the bottom margin (available only for plain paper).
  - **Centered** places the image in the center of the printable area.
7. After making your settings, click **OK**.

**Note:** Many application settings override the printer's page setup options. Always verify settings to get the results you expect.

If you need more information about print options, click the ? button on any dialog box.

## Choosing Page Setup Options for Roll Paper and Borderless Printing

Although you can select borderless printing for cut sheets as well as roll paper, you can only print to the side edges on cut sheets. Margins are required at the top and bottom of the page. Follow these steps to print on roll paper:

1. Open the file you want to print, and select **Page Setup** in your application. You see the page setup dialog box:

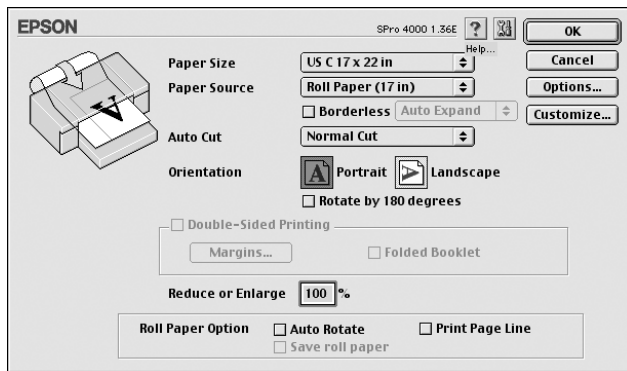

2. Select the size of your image for the **Paper Size**. Or, to make better use of roll paper, click **Customize**.

You see the custom page size window:

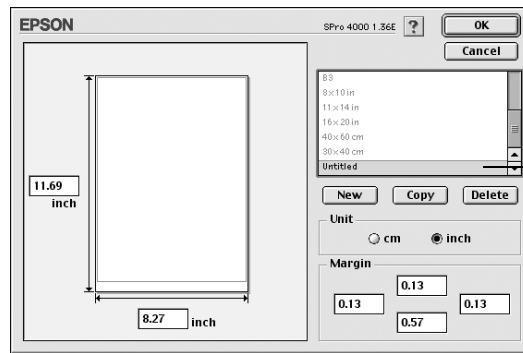

Double-click here,  
then enter a name  
for the custom size

Click **New**, double-click **Untitled**, then enter a name for the custom size. Enter the size (inches or centimeters). You can also enter margin settings for your custom paper size or for any standard paper size.

3. Select one of the Roll Paper sizes from the **Paper Source** list.

Select **Roll Paper (Banner)** to print a series of continuous images without any margin space between them.

**Note:** If your application has margin settings, make sure they're turned off.

4. If you want to print borderless images, select **Borderless**.

Note the following limitations on borderless printing:

- Borderless printing takes longer than normal printing.
- Margins are required at the top and bottom of the page on cut sheets. Full borderless printing is available on roll paper only.

Choose **Auto Expand** or **Retain Size** from the pull-down menu:

- **Auto Expand** enlarges your image (up to 3%) to fit the size of the paper.
- **Retain Size** prints your image at the size you specify in your application. You need to size it about 1/4 inch wider than the paper width if you want to print without borders.

5. Choose one of the following **Auto Cut** settings:
  - **Normal Cut** allows margin space at the top and bottom of each image.
  - **Double Cut** extends the space between the images and trims each print individually. This provides the cleanest edge for borderless printing.
  - **Single Cut** causes the images to be printed end-to-end and saves paper. With borderless printing, you may see a sliver of the previous or next image.
  - **Off** disables automatic cutting. Choose this setting if you want to operate the cutter manually, print multiple print jobs without cutting, or if you are printing on heavy media that must be cut with scissors. See page 33 for instructions on using the button to operate the cutter.
  
6. Make the settings you want for **Orientation** and **Reduce or Enlarge**.
  
7. Select any of the following options:
  - **Auto Rotate** saves paper if your document length is shorter than the printable width of the paper roll. Your image is rotated automatically by 90 degrees and printed crosswise.
  - **Print Page Line** prints trim lines on the right and bottom edges of your pages.
  - **Save Roll Paper** saves paper by not feeding the blank portion of the last page of your document. Available only when you've selected **Roll Paper (Banner)** as the Paper Source.
  
8. After making your settings, click **OK**.
  
9. Print your image.

**Note:** These settings override settings made through the control panel.

## Choosing Basic Print Options

Once you have selected your page setup options, you need to select printing options. The EPSON driver offers automatic settings that optimize print quality and speed when you're using EPSON media. You can also choose advanced settings for more control over your printer and color management options, as described on page 64.

1. Select **Print** in your application. A dialog box like the following appears:

This area shows the current settings, but you can't change them from here

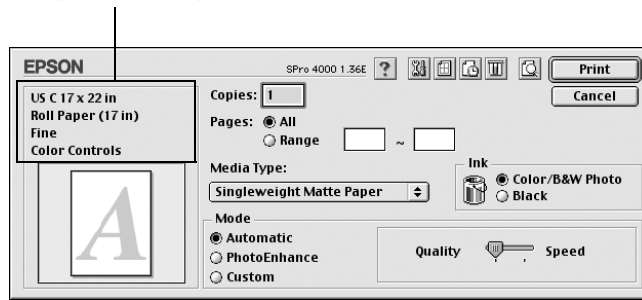

2. Choose the number of **Copies** and indicate which **Pages** you want to print.
3. Select the **Media Type** that corresponds to the paper you are printing on. If you are using a color-managed workflow, make sure you choose media type and resolution settings that match the ICC profile you are using.

**Note:** Check the web site (<http://prographics.epson.com>) or your authorized EPSON dealer for other media that may be available.

The settings followed by (250) are for roll paper or 17-inch wide sheets. Choose a setting without the (250) designation when you print on smaller sheets. For PremierArt Water Resistant Canvas for Epson, choose the **Watercolor Paper - Radiant White** setting.

If your paper is not listed, check the instructions included with the paper, or check the EPSON web site (<http://prographics.epson.com>). If you are using non-EPSON media, choose the closest setting. You may have to experiment to determine the best setting for your media.

**Tip:** For black-and-white photography, use the **Color/B&W Photo** setting (don't select **Black**). Use a ColorSync workflow for best results.

4. For the ink type, select **Color/B&W Photo** if you're printing either a color or black-and-white photo image. Select **Black** only if you're printing line drawings or other non-photographic images.

5. Set the **Mode** option as follows:





- Click **Automatic** to have the printer driver analyze the contents of your image or file and make the appropriate printing adjustments. If a **Quality/Speed** slider appears in the Mode box, set it according to the priorities of your print job.
- Click **PhotoEnhance** to have the driver automatically adjust the contrast, saturation, and brightness. You can also select automatic enhancements or filters for **People, Nature, Soft Focus, Sepia** or **Digital Camera Correction**.
- Click **Custom** and then choose one of the following settings, or click the **Advanced** button and see page 64 for more information.

The two **Advanced Photo** settings let you print at either 1440 dpi (**Advanced Photo**) or 2880 dpi, the highest resolutions available.

The **Text/Graph** setting intensifies colors and lightens the midtones and highlights for non-photographic output.

The **ColorSync** setting applies color management based on the printer's ICC profile, using the perceptual rendering intent.

6. Choose from the following buttons to access additional features:

- Click  to access the printer monitoring and maintenance utilities. See page 69 for more information about the Status Monitor utility. See Chapter 4 for details about the maintenance utilities.
- Click  if you want to reduce your image to fit the page or for other layout options.
- Click  to turn on background printing. This lets you work on your Macintosh while you're printing and use the Monitor IV utility. See page 67 for more information.
- Click  to check your ink levels.
- Click  and then click the **Preview** button to preview your print.

7. When you're finished choosing print options, click **Print**.

## Choosing Advanced Print Options

The advanced print settings give you complete control over your printing environment. Use these settings to experiment or to fine-tune a range of options to meet your individual needs.

1. Follow steps 1 through 4 on page 62.
2. Click **Custom** and then click **Advanced**. You see a dialog box like the following:

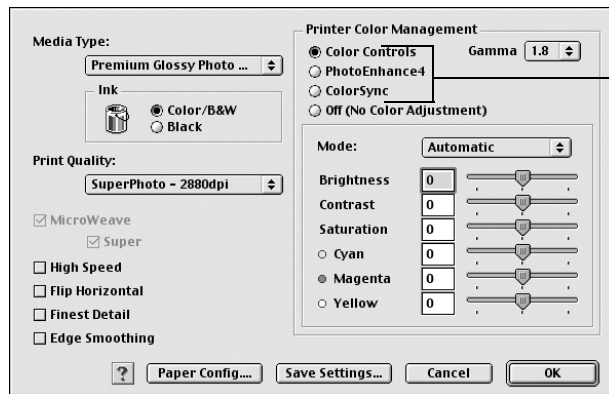

These three settings give you different options on the lower part of the screen

3. If necessary, you can change your **Media Type** and **Ink** settings.

**Note:** The Print Quality settings available depend on the Media Type you selected. Choose lower print quality for faster printing, or SuperPhoto - 2880dpi for best quality.

4. Choose one of the following **Print Quality** settings:
  - **Draft** to save ink
  - **Normal - 360dpi** for faster printing and everyday needs
  - **Fine - 720dpi** for photo lab quality photos and prints
  - **SuperFine - 1440dpi** for better than photo lab quality
  - **SuperPhoto - 2880dpi** for the highest quality photos and prints; provides an astonishing level of photographic quality

5. Choose any of the following:
  - **Microweave** or **Super MicroWeave** to eliminate unwanted banding effects. If you notice banding with the standard **MicroWeave** setting, select **Super MicroWeave**.
  - **High Speed** for fast, bidirectional printing at lower quality.
  - **Flip Horizontal** for printing a mirror image of your file. Use with backlight film.
  - **Finest Detail** for sharper edges when printing text, graphics, and line art.
  - **Edge Smoothing** to improve the quality of low-resolution images.
  
6. Choose one of the following Color Management settings:
  - **Color Controls** lets you specify individual values for adjusting brightness, contrast, saturation, and CMY inks, or choose from the three Color Adjustment modes. You can also choose from three Gamma settings.
  - **PhotoEnhance4** allows you to correct noise and other problems common to digital camera images or choose special tone and effect settings.
  - **ColorSync** lets you select from three Rendering Intent settings for mapping colors to your printer's **EPSON Standard** profile. In most cases, you will get better results by applying color management in your application, rather than in the printer driver.
  - **No Color Adjustment**  
Disables color management in the printer driver. Choose this mode when you use a color managed workflow in Photoshop or other software applications.

**Tip:** If you turn off color management, you can use the Color Density setting to control the ink density.

7. If you are using non-EPSON media and you need to fine-tune its performance, click the **Paper Config** button. You see this screen:

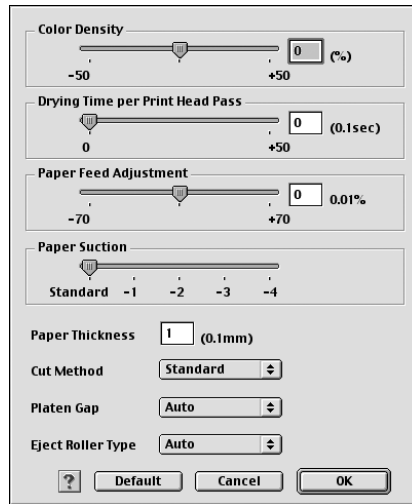

8. Select the correct settings to match your ICC profile. These settings override any paper configuration settings you may have made using the printer's control panel.
- **Color Density** lets you control the ink saturation level (for example, when you turn off color management in your printer software).
  - **Drying Time per Print Head Pass** lets you print with non-EPSON media and avoid smearing the ink. You can make the print head wait up to 5 seconds after each pass to allow ink to dry on the page.
  - **Paper Feed Adjustment** helps eliminate banding. Choose a lower value if you see white lines on your prints, or a higher value if you see dark lines.
  - **Paper Suction** lets you decrease the paper suction level when printing on thinner media (less than 12 lb), such as CAD drafting paper or backlight film.
  - **Paper Thickness** eliminates vertical banding and creates a sharper image when printing on unusually thick or thin paper.

- **Cut Method** decreases the cutting blade pressure for thinner media, and adjusts the speed for thick media. You may need to experiment to determine the best setting for your paper.
  - **Platen Gap** lets you fine-tune the setting for various paper thicknesses.
  - **Eject Roller Type** lets you define the eject roller for printing with non-EPSON media. You may need to experiment to determine the best setting for your paper.
9. Click **Save Settings** if you want to have your advanced settings available for reuse. Then type a name for the group of settings and click **Save**. The name is added to your list of custom settings.
  10. When you're finished setting advanced printer options, click **OK**.

## Managing Print Jobs

Your printer comes with several utilities that let you check on your print jobs and schedule, cancel, pause, or restart them. First you need to set up background printing, so you can continue to work on your Macintosh while a file is being printed. Note that background printing is slower and may also slow down your system.

You can set up background printing from the Chooser, as described on the *Start Here* sheet, or you can use the background printing button on the print dialog box. Follow these steps to set up background printing:

1. Open the file you want to print and select **Print** in your application.
2. Click the  background printing button. You see the following dialog box:

Not available if background printing is turned off

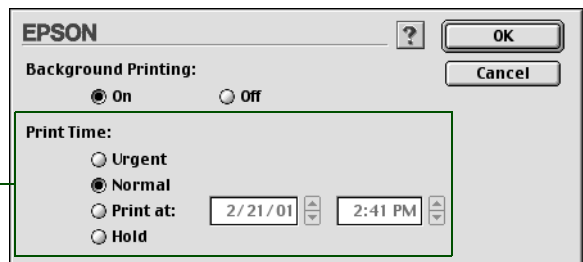

3. To turn background printing on, click the **On** button.
4. To select a priority for your print job in the queue of jobs waiting to print, click one of the following:
  - **Urgent** to print before any Normal priority job
  - **Normal** to print in the order the job is received
  - **Print at:** to print at the specific time you enter in the day and time in the fields to the right
  - **Hold** to hold the print job in the print queue until you're ready to release it using Monitor IV; see the following section for details.
5. Click **OK** to save your settings and return to the printer settings dialog box.
6. Click **Print** to print your document.

If you selected **Print at:** or **Hold**, your document is spooled, but held in the print queue until the print time specified or until released using Monitor IV, as described in the following section.

## Monitoring Your Print Job

The Monitor IV utility lets you prioritize and control your print jobs as well as monitor their progress.

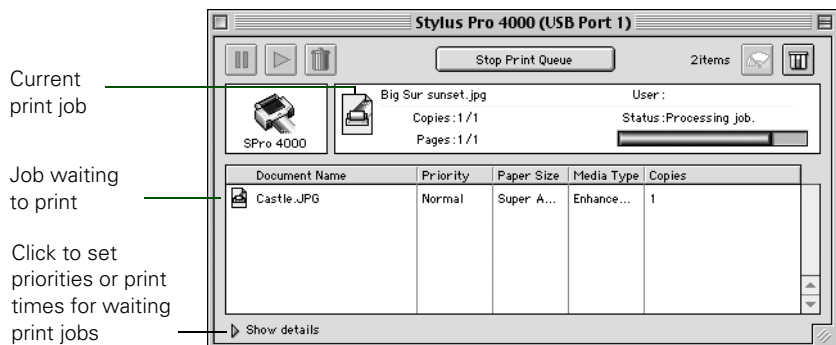

After you send a print job, click the current application icon at the right end of the menu bar and select **EPSON Monitor IV**. You see a window like the following:

**Note:** You must turn on background printing to view the EPSON Monitor IV window. See page 67 for instructions, or use the Chooser.





The progress bar tracks the current print job. To cancel, pause, or restart a print job, click the document's name, then click one of the following buttons:

**Note:** If you see a stop sign icon and the message Print queue on hold in the EPSON Monitor IV dialog box, select **Start print queue** from the Printer menu to release the queue and resume printing.

- Click  to cancel.
- Click  to restart.
- Click  to pause.

You can also do the following:

- Double-click a file in the list to preview it.
- Double-click Copies to change the number of copies to be printed.
- Click  to check your ink levels.
- Click  to start the print head cleaning utility. See page 92 for more information about the cleaning utility.

## Checking Printer Status

The Status Monitor utility lets you check the levels of ink in your printer and configure error messages and other features of printer operation. Follow these steps to check ink levels:

1. Click the  utility button on the print or page setup dialog box. You see the utility menu:

Click to open the Status Monitor utility

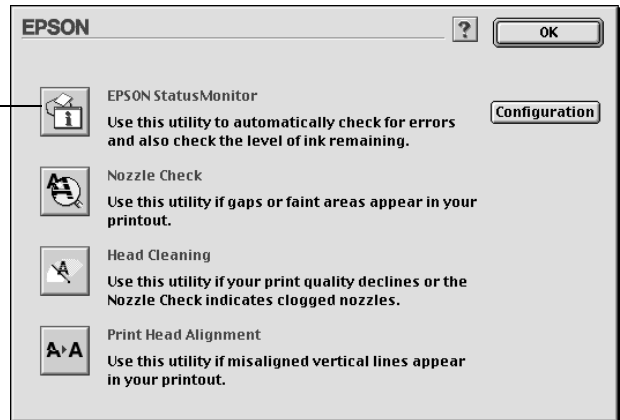

2. Click the EPSON StatusMonitor icon.

The software checks the amount of ink remaining in the printer and displays the Status Monitor window:

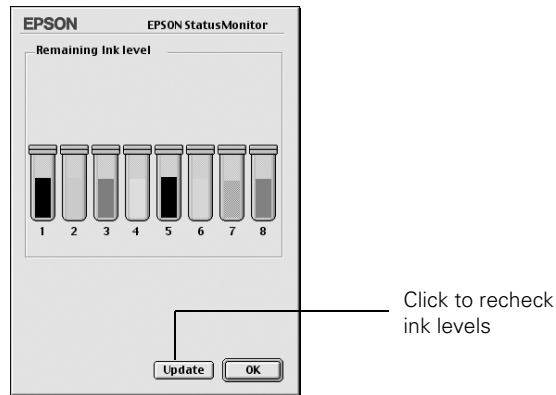

3. To recheck the ink level check, click the **Update** button. To close the Status Monitor, click **OK**.

## Selecting Configuration Options

You can configure the way you want the printer to handle error and warning messages, ink level checks, and print file storage in the Configuration Settings dialog box. Follow these steps:

1. Click the  utility button on the print or page setup dialog box. You see the utility menu.
2. Click the **Configuration** button.

You see the Configuration Settings dialog box:

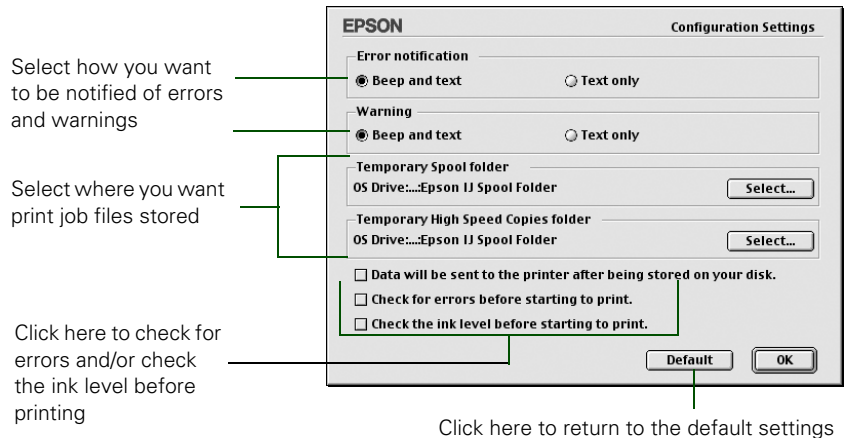

3. Select from the following configuration options:

**Note:** Warning messages allow printing to continue. Error messages are more serious and cause printing to stop.

- **Error notification** lets you choose whether you want your system to beep and display error message text or just display text if your printer encounters an error.
- **Warning** lets you choose whether warning messages beep and display text or display text only.
- **Temporary Spool folder** and **Temporary High Speed Copies folder** let you select the folders on your hard disk that store the temporary files created when you send a job to the printer. Click the **Select** button to change the folder from the default folder shown.
- **Data will be sent to the printer after being stored on your disk** prevents print head pausing. Normally, graphics are sent in rectangular bands. When you select this option, your Macintosh stores the entire image on its hard drive and then sends it to the printer as a whole (recommended only for older Macintosh systems).
- The last two checkboxes let you choose to have your software check for errors or low ink levels before starting your print job.

4. When you're finishing changing your configuration options, click **OK** to return to the utility menu.

## Sharing Your Printer on a Network

If the printer is connected to a Macintosh computer on an AppleTalk® network, other computers on the network can also access the printer.

1. On the Macintosh to which the printer is connected, open the Chooser from the Apple® menu, click the printer name, and select the port where the printer is connected.
2. Click **Setup**. You see the Printer Sharing Setup window.
3. Select **Share this Printer**, and type in the printer name and password information as needed. Click **OK**.
4. Close the Chooser.
5. On other Macintosh computers on the network, open the Chooser from the Apple menu.
6. Click the printer name and select the shared printer. Only printers on the current AppleTalk zone are available.

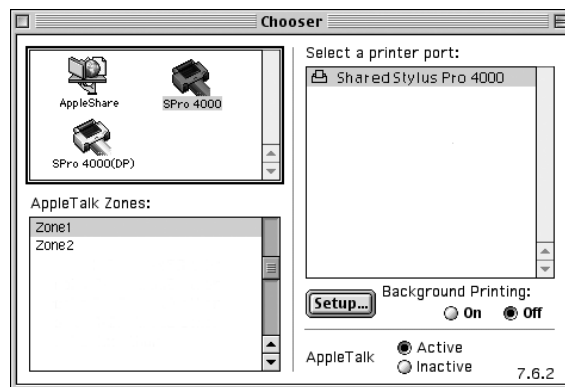

7. If a password box opens, enter the password for the printer and click **OK**.
8. Turn background printing on and close the Chooser.

## Chapter 3: Printing with EPSON Drivers for Windows

Your Stylus Pro 4000 comes with drivers and utilities that let you print and manage print jobs in non-PostScript mode. ICC profiles are included, so you can use the color management features in Photoshop or other applications, or in the driver itself.

A color-managed workflow using Adobe Photoshop will give you the most accurate colors and best photographic output from your EPSON Stylus Pro 4000. You need to make sure your Photoshop color settings are optimized for your printer, as described on the *Mastering Your Printer* CD-ROM.

You can create your own profiles if you have the required hardware and software, or you can have them created by a service bureau. Make sure any profiles you want to use are located in the standard folder for your operating system. When you install the EPSON printer driver, the ready-made profiles are automatically copied to the right folder.

This chapter includes the following information:

- Choosing basic print options
- Choosing paper and layout options
- Choosing advanced print options
- Managing print jobs
- Sharing your printer on a network

## Choosing Basic Print Options

Before you print, you need to set basic printing properties. Make sure you have installed the EPSON driver and utilities from the CD-ROM.

The driver offers automatic settings that optimize print quality and speed when you're using EPSON media. You can also choose advanced settings for more control over your printer and color management options, as described on page 80.

Follow these steps to make basic settings:

1. Start an application, open the file you want to print, and select **Print** in your application. You see the **Print** window.
2. Make sure your printer is selected, then click the **Properties** button. If you see a **Setup**, **Printer**, or **Options** button, click it instead. Then click **Properties** on the next screen. You see a window like the following:

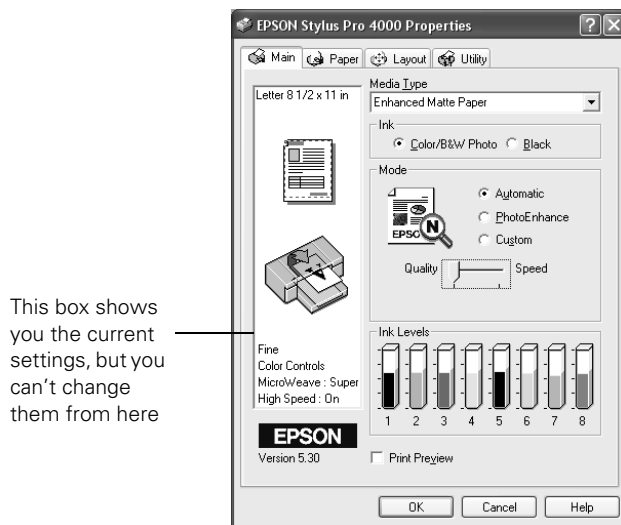

**Note:** If you need more information about print options, you can click the **Help** button on any screen.

3. Select a **Media Type** setting that corresponds to the paper you are printing on. If you are using a color-managed workflow, make sure you choose media type and resolution settings that match the ICC profile you are using.

**Note:** Check the web site (http://prographics.epson.com) or your authorized EPSON dealer for other media that may be available.

The settings followed by (250) are for roll paper or 17-inch wide sheets. Choose a setting without the (250) designation when you print on smaller sheets. For PremierArt Water Resistant Canvas for Epson, choose the **Watercolor Paper - Radiant White** setting.

If your paper is not listed, check the instructions included with the paper, or check the EPSON web site (http://prographics.epson.com). If you are using non-EPSON media, choose the closest setting. You may have to experiment with different settings to determine which one is best for the media you're using.

4. For the Ink setting, select **Color/B&W Photo** if you're printing either a color or black-and-white photo image. Use a color-managed workflow for best results. Select **Black** only if you're printing line drawings or other non-photographic images.
5. Set the **Mode** option as follows:
  - Click **Automatic** to have the printer driver analyze the contents of your image or file and make the appropriate printing adjustments. If a **Quality/Speed** slider appears in the Mode box, set it according to the priorities of your print job.
  - Click **PhotoEnhance** to have the driver automatically adjust the contrast, saturation, and brightness. You can also select automatic enhancements or filters for **People, Nature, Soft Focus, Sepia** or **Digital Camera Correction**.
  - Click **Custom**, and then choose one of the settings shown at the left.

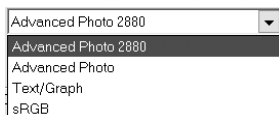

**Note:** In most cases, you will get better results by applying color management in your application, rather than in the printer driver. To do this, you must turn off color management in the printer driver, as described on page 82.

The two Advanced Photo settings let you print at either 1440 dpi (**Advanced Photo**) or 2880 dpi, the highest resolutions available.

The **Text/Graph** setting intensifies colors and lightens the midtones and highlights for non-photographic output.

The **sRGB** setting adjusts colors using the small-gamut sRGB (standard red green blue) color space. Best for color matching with other sRGB devices, or for images designed for the Web.

- Click **Custom**, then click the **Advanced** button to turn off color management in the printer driver or access additional settings, as described on page 80.

- When you're finished choosing print options, click the **Paper** tab and follow the instructions on page 76 for choosing paper and layout options.

**Note:** Many application settings override settings in the printer driver. Always verify settings to get the results you expect.

## Choosing Paper and Layout Options

You can select a variety of settings for margins, orientation, paper saving, sizing your image, and double-sided printing. Follow the instructions below to select settings for cut sheet paper, or the instructions on page 78 for roll paper.

## Choosing Cut Sheet Paper Options

- On the Properties window, click the **Paper** tab. You see this window:

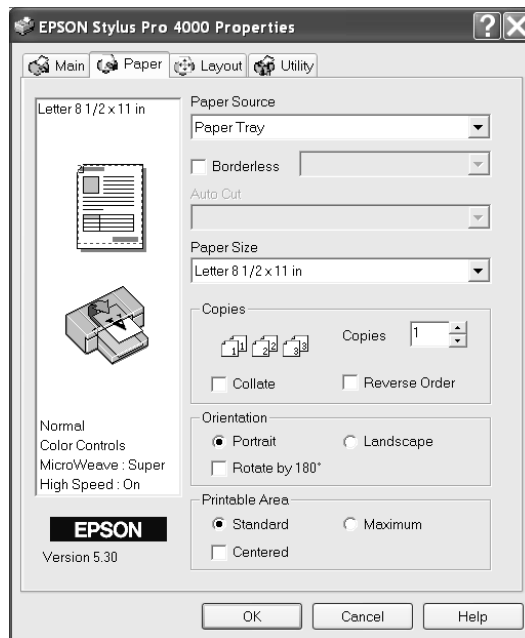

- Select the paper source you're using (**Paper Tray**, **Roll Paper**, **Roll Paper (Banner)**, or **Manual Feed**) from the **Paper Source** list.

For more information about printing on roll paper, see page 78,

3. If you want to print to the edges of the page, click **Borderless**. Note that borderless printing applies only to the left and right sides of the page on cut sheets; margins are required at the top and bottom of the page. For full-bleed borderless printing, use roll paper, as described on page 78.

Choose **Auto Expand** or **Retain Size** from the pull-down menu:

- **Auto Expand** enlarges your image (up to 3%) to fit the size of the paper.
  - **Retain Size** prints your image at the size you specify in your application. You need to size it about 1/4 inch wider than the paper width if you want to print without borders.
4. Select the **Paper Size** loaded in the printer.
  5. Make the settings you want for **Copies**, **Orientation**, and **Printable Area**.
    - **Standard** makes the bottom margin larger than the top and sides.
    - **Maximum** reduces the bottom margin (available only for plain paper).
    - **Centered** places the image in the center of the printable area.
  6. If you want to reduce or enlarge your image or print on both sides of the paper, click the **Layout** tab. See your electronic *Reference Guide* for more information about double-sided printing.
  7. After making your settings, click **OK**.

**Note:** Many application settings override settings in the printer driver. Always verify settings to get the results you expect.

## Choosing Roll Paper Options

Follow these steps to print on roll paper and select settings for borderless printing and automatic cutting:

1. On the Properties window, click the **Paper** tab. You see this window:

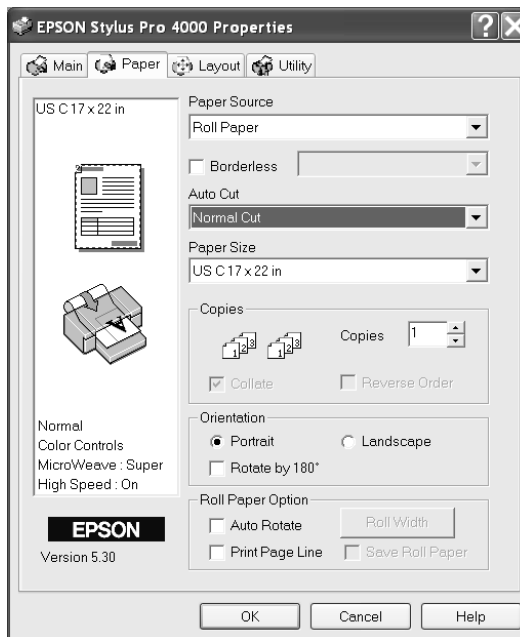

2. Select **Roll Paper** or **Roll Paper (Banner)** from the **Paper Source** list.

The **Roll Paper (Banner)** setting allows you to print a series of continuous images without any margin space between them. This option is not available with all applications.

3. If you want to print without margins, click **Borderless**. Note that borderless printing takes longer than normal printing.

Choose **Auto Expand** or **Retain Size** from the pull-down menu:

- **Auto Expand** enlarges your image (up to 3%) to fit the size of the paper.
- **Retain Size** prints your image at the size you specify in your application. You need to size it about 1/4 inch wider than the paper width if you want to print without borders.

4. Choose one of the following **Auto Cut** settings:

- **Off** disables automatic cutting. Choose this setting if you want to operate the cutter manually, print multiple print jobs without cutting, or if you are printing on heavy media that must be cut with scissors. See page 33 for instructions on operating the cutter manually.
- **Single Cut** causes the images to be printed end-to-end and saves paper. With borderless printing, you may see a sliver of the previous or next image.
- **Normal Cut** allows margin space at the top and bottom of each image.
- **Double Cut** extends the space between images and trims each print individually. This provides the cleanest edge for borderless printing.

5. Select the size of your image as the paper size.

**Tip:** Creating a user-defined paper size generally lets you make the best use of your roll paper.

Or, to make the best use of your paper, you can create a custom paper size. Select **User Defined**. You see this screen:

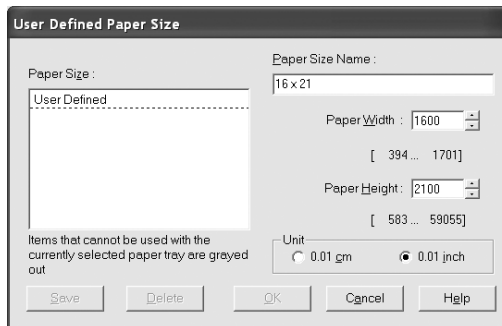

Type a name for your custom size, then enter the size in hundredths of an inch (or centimeters) and click **Save**, then click **OK**.

6. If you are printing with margins, set the following options:
  - **Auto Rotate** saves paper if your document length is shorter than the printable width of the roll. The document is automatically rotated 90 degrees and printed crosswise. Be sure to click **Roll Width** and select the width of your roll paper.
  - **Print Page Line** prints trim lines on the right and bottom edges of your pages.
  - **Save Roll Paper** saves paper by not feeding the blank portion of the last page of your document. Available only if you've selected **Roll Paper (Banner)** as the Paper Source.
7. Make the settings you want for **Copies** and **Orientation**.
8. If you want to reduce or enlarge your image, click the **Layout** tab. See the electronic *Reference Guide* for more information on layout settings.
9. After making your settings, click **OK**.

**Note:** Select **Landscape** when you want to rotate your image 90°.

## Choosing Advanced Print Options

The advanced settings give you complete control over your printing environment. If you are using color management settings in Photoshop or another application, it is very important to access the advanced settings and turn off color management in the printer driver, as described on page 82.

1. Follow steps 1 through 4 beginning on page 74.
2. Click **Custom** and then click **Advanced**.

You see a window like the following:

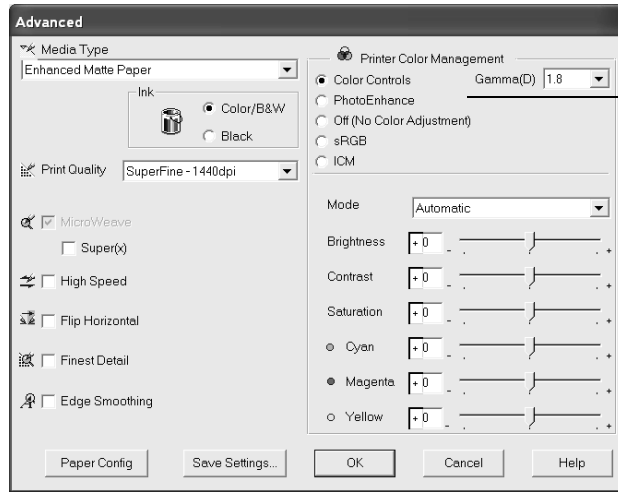

These settings give you different options on the lower part of the screen

**Note:** The Print Quality settings available depend on the Media Type you selected. Choose lower print quality for faster printing, or SuperPhoto - 2880dpi for best quality.

3. If necessary, you can change your **Media Type** and **Ink** settings.
4. Choose one of the following **Print Quality** settings:
  - **Draft** to save ink
  - **Normal - 360dpi** for faster printing and everyday needs
  - **Fine - 720dpi** for high quality photos and prints (deselect the **High Speed** checkbox to achieve photo lab quality)
  - **SuperFine - 1440dpi** for better than photo lab quality
  - **SuperPhoto - 2880dpi** for the highest quality photos and prints; provides an astonishing level of photographic quality
5. Choose any of the following:
  - **High Speed** for fast, bidirectional printing at lower quality.
  - **Flip Horizontal** for printing a mirror image of your file. Use with backlight film.
  - **Finest Detail** for sharper edges when printing text, graphics, and line art.
  - **Edge Smoothing** to improve the quality of low-resolution images.

**Tip:** If you turn off color management, you can still control the ink density, as described on page 83.

6. Choose one of the following Color Management settings:
  - **Color Controls** lets you specify individual values for adjusting brightness, contrast, saturation, and CMY inks, or choose from the three Color Control modes. You can also choose from three Gamma settings, which control image contrast by modifying the midtones and midlevel grays.
  - **PhotoEnhance** allows you to correct noise and other problems common to digital camera images or choose special tone and effect settings.
  - **Off (No Color Adjustment)** disables color management in the printer driver. Choose this mode when you use a color managed workflow in Photoshop or other software.
  - **sRGB** adjusts colors using the small-gamut sRGB (standard red green blue) color space. Best for color matching with other sRGB devices, or for images designed for the Web.
  - **ICM** adjusts colors based on the printer's ICC profile, using the Image Color Matching system and the printer's EPSON Standard profile. In most cases, you will get better results by applying color management in your application, rather than in the printer driver.
7. To access the paper configuration settings, click the **Paper Config** button.

**Note:** Be sure to check the Color Density setting. You may need to change it if your profile was created to optimize D-max and color gamut.

You see the following:

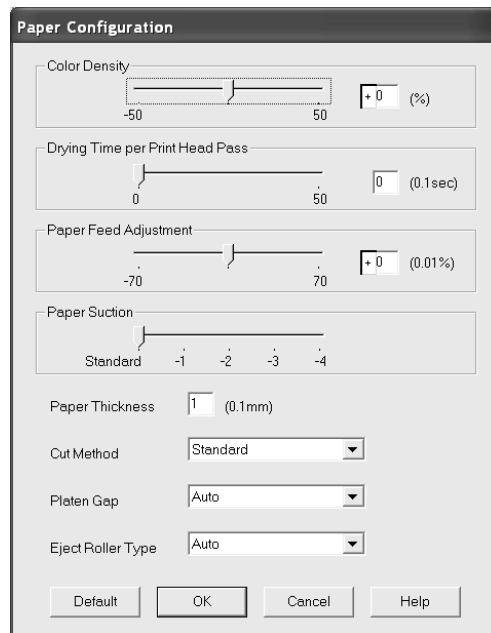

Select the correct settings to match your ICC profile. These settings override any paper configuration settings you may have made using the printer's control panel.

- **Color Density** lets you control the ink saturation level (for example, when you turn off color management in your printer software).
- **Drying Time per Print Head Pass** lets you print with non-EPSON media and avoid smearing the ink. You can make the print head wait up to 5 seconds after each pass to allow ink to dry.
- **Paper Feed Adjustment** helps eliminate banding. Choose a lower value if you see white lines on your prints, or a higher value if you see dark lines.
- **Paper Suction** lets you decrease the paper suction level when printing on thinner papers (less than 12 lb), such as CAD drafting paper or backlight film.
- **Paper Thickness** eliminates vertical banding and creates a sharper image when printing on unusually thick or thin paper.

- **Cut Method** decreases the cutting blade pressure for thinner media, and adjusts the speed for thick media. You may need to experiment to determine the best setting for your paper.
  - **Platen Gap** lets you fine-tune the setting for various paper thicknesses.
  - **Eject Roller Type** lets you define the eject roller for printing with non-EPSON media. You may need to experiment to determine the best setting for your paper.
8. Click **Save Settings** if you want to have your advanced settings available for reuse. Then type a name for the group of settings and click **Save**. The name is added to your list of custom settings.
  9. When you're finished setting advanced printer options, click **OK**.

## Managing Print Jobs

Your printer comes with several utilities that let you check on your print jobs and cancel, pause, or restart them.

The Progress Meter opens each time you send a print job. Status Monitor 3, which appears on the taskbar when you print, lets you check the printer's status and monitor print jobs.

## Using the Progress Meter

After you send a print job, the Progress Meter window appears:

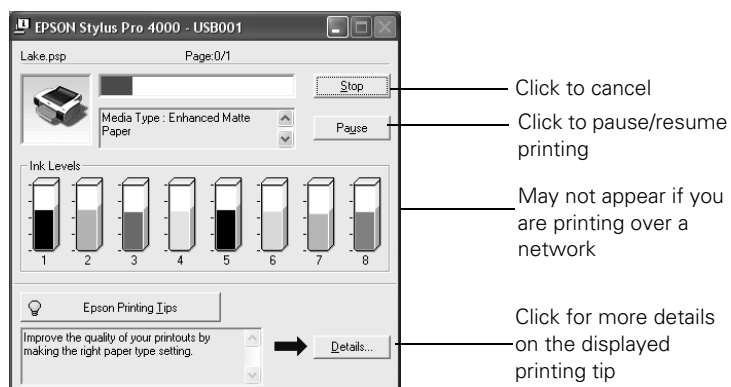

You can use the buttons to cancel, pause, or restart your print job. You also see how much ink you have left and view printing tips.

If you don't want the Progress Meter to appear, you can turn it off. See page 86 for instructions.

## Setting Monitoring Preferences and Optimizing Print Speed

You can choose when and how you want to be notified of problems, whether you want a Status Monitor 3 icon to appear on your Windows taskbar, and whether you want to allow monitoring by other users who share the printer. You can also use the Speed and Progress utility to improve printing speed.

1. Do one of the following:
  - **Windows XP:** Click **Start** and select **Printers and Faxes**. Right-click your printer icon and select **Printing Preferences**.
  - **All other versions of Windows:** Click **Start**, point to **Settings**, then select **Printers**. Right-click your printer icon and select **Properties**, **Document Defaults**, or **Printing Preferences**.
2. Click the **Utility** tab, then click the **Speed & Progress** button. You see the **Speed & Progress** window:

**Note:** If you want to disable display of the progress meter during printing, you can click the **Show Progress Meter** checkbox to deselect it.

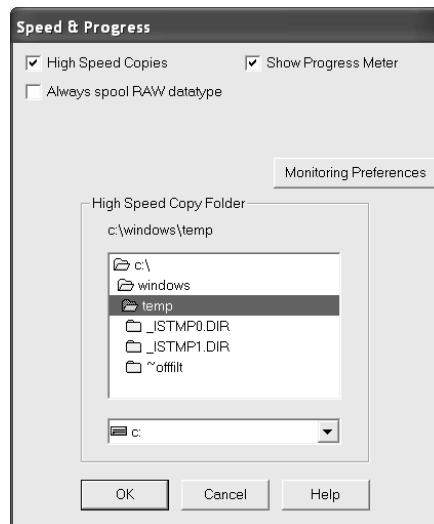

3. Select from the following options:
  - **High Speed Copies** speeds up printing of multiple copies of the same document using hard disk space as a cache. If you have multiple hard drives, you can select a high speed copy folder for storing copies.
  - **Show Progress Meter** lets you control whether or not the Progress Meter is displayed when you send a print job.
  - **Always spool RAW datatype** (Windows 2000, XP, and NT only) lets you spool documents using the RAW format instead of the EMF (metafile) format. Because the RAW format requires fewer resources, printing is faster and you can avoid certain problems, such as insufficient memory or disk space.
4. Click the **Monitoring Preferences** button. You see the Monitoring Preferences window:

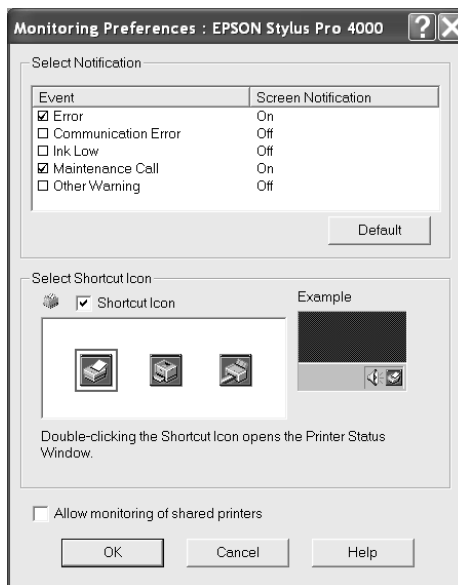

5. Select the Notification options you want to use.

6. If you want to have the Status Monitor 3 icon appear in your Windows taskbar, click the **Shortcut Icon** checkbox. Then select the icon to use.

After you enable the shortcut, you can simply double-click the icon to open the Status Monitor 3 window or right-click it, then select **Monitoring Preferences** in the pop-up menu.

7. Select **Allow monitoring of shared printers** if your printer is shared and you want to let other users monitor it.
8. Click **OK** to save your settings.
9. Click **OK** to close the Speed & Progress dialog box and return to the Utility menu. Then click **OK** again to exit the Printers utility.

## Sharing Your Printer on a Network

If your printer is connected to a computer on a network, other computers on the network can also access the printer. Follow these instructions for sharing your printer in Windows XP. If you're using a different version of Windows, see the electronic *Reference Guide* for instructions.

1. Click **Start > Printers and Faxes**. Right-click your printer icon and select **Sharing**.
2. Select **Share this printer**, type the name in the Share name box, then click **OK**.

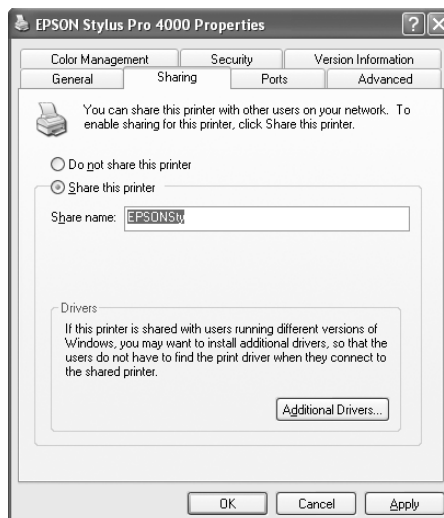

3. Install the printer driver from the software CD-ROM on the other computers that will access the printer over the network.
4. On each computer that will access the printer, click **Start > Printers and Faxes**. Right-click the printer icon and select **Properties**.
5. Click the **Ports** tab. You see a window like the following:

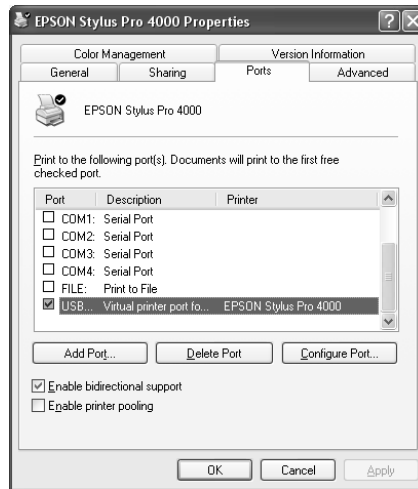

6. Click **Add Port**, select **Local Port**, then click **New Port**.
7. In the **Port Name** box, type the name of computer that is connected to the printer and the name of the shared printer (as shown below), then click **OK**.

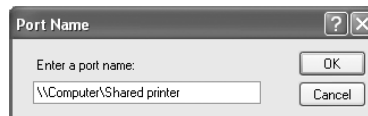

8. Close the Printer Ports window to return to the Ports tab. Make sure the new port is added and the check box is selected. Then click **OK**.

## Chapter 4: Maintaining and Transporting the Printer

The EPSON Stylus Pro 4000 requires very little maintenance to keep working its best. This chapter describes the following routine procedures:

- Checking printer status and part life
- Checking and cleaning the print head
- Aligning the print head
- Replacing ink cartridges
- Using the maintenance mode
- Replacing the paper cutter blade
- Replacing the maintenance tank
- Cleaning the printer
- Transporting or storing the printer
- Uninstalling and reinstalling printer software

In addition to the features described in this chapter, you can also use the SelecType menu system on the printer to fine-tune a variety of printer settings. For more information, see the electronic *Reference Guide* included on the CD-ROM that came with your printer.

**Note:** To test the print quality, see page 75 for instructions on printing a nozzle check.

### Checking Printer Status and Part Life

Using the SelecType menus, you can check the amount of ink remaining, the total number of prints, and the status of your cutter blade, maintenance tank, and other printer parts. You can either print out a status check, or you can view the printer's status on the LCD panel.

### Printing Status Information

The status check sheet shows some of the current default settings, the amount of ink remaining in each cartridge, the page count, and the status of various printer parts.

Follow these steps to print the status check sheet:

1. Make sure paper is loaded in the tray.

**Note:** You can replace the ink cartridges, cutter blade, and maintenance tank yourself. Other printer parts need to be replaced by an authorized EPSON service technician.

2. Press the **Menu** >/< button. You see **PRINTER SETUP**.
3. Press the **▼** button so you see **TEST PRINT**, then press **Menu** >/<. You see **NOZZLE CHECK**.
4. Press **▼** so you see **STATUS CHECK**, then press **Menu** >/<. You see **PRINT**.
5. Press **Menu** >/< again to start printing.

The amount of ink left or the component life is indicated as follows:

E\*\*\*\*\*F = 100–81% ink or service life remaining

E\*\*\*\* F = 80–61%

E\*\*\* F = 60–41%

E\*\* F = 40–21%

E\* F = 20–11%

% = less than 10% ink or service life remaining

## Viewing Status Information

To view printer status information instead of printing it, follow these steps:

1. Press the **Menu** >/< button. You see **PRINTER SETUP**.
2. Press the **▼** button until you see **PRINTER STATUS**, then press **Menu** >/<. You see **VERSION**.
3. Do one of the following:
  - To check the amount of ink left, press **▼** until you see **INK LEFT**, then press **Menu** >/<. The status of the first cartridge (MK, or matte black) is displayed, using the E\*\*\*\*\*F symbols described below. Continue pressing **▼** to see the status of the remaining cartridges.
  - To check how much of the maintenance tank has been used, press **▼** until you see **MAINT TANK**, then press **Menu** >/<. The status of the tank is displayed, using the E\*\*\*\*\*F symbols described below.
  - To check the amount of ink used (in milliliters) and paper used (in square meters), press **▼** until you see **USAGE COUNT**, then press **Menu** >/<.

**Note:** You can replace the ink cartridges, cutter blade, and maintenance tank yourself. Other printer parts need to be replaced by an authorized EPSON service technician.

You can change the units of measurement from meters to inches and feet by using the maintenance mode on the printer's control panel. See page 84 for instructions.

- To check job history, press **▼** until you see **JOB HISTORY**, then press **Menu** **➤**. For each job saved in the printer, you see the ink used (in milliliters), paper used (in square meters), and the time for the print job in seconds. The most recent job is saved as No. 0.
- To check the total number of prints, press **▼** until you see **TOTAL PRINTS**, then press **Menu** **➤**.
- To check the status of other printer parts, press **▼** until you see **SERVICE LIFE**, then press **Menu** **➤**. The status of the cutter is displayed, using the **E\*\*\*\*\*F** symbols described below. Continue pressing **▼** to see the status of the carriage motor, paper feed motor, print head, and cleaning unit.

The status of the ink and printer parts is indicated with these symbols:

**E\*\*\*\*\*F** = 100–81% ink or service life remaining  
**E\*\*\*\* F** = 80–61%  
**E\*\*\* F** = 60–41%  
**E\*\* F** = 40–21%  
**E\* F** = 20–11%  
**%** = less than 10% ink or service life remaining

4. Press the **|||** Pause button to exit the menu.

For more information about the Printer Status menu, see your electronic *Reference Guide*.

**Note:** You can run a cleaning cycle by holding down the **Menu** button for three seconds. You can also use the printer's menus to run a power cleaning cycle. See page 77 for details.

## Checking and Cleaning the Print Head

If your printed image is unexpectedly faint or dots are missing from the printout, you should check the print head to see if any nozzles are clogged.

You can check the print head and turn on the Auto Cleaning feature at the same time, using your printer utility software. This enables the printer to print a nozzle check pattern, read it, and automatically run a cleaning cycle if necessary.

1. Make sure paper is loaded in the paper tray.

2. Do one of the following to access the printer utilities:
  - **Mac OS X:** Open the EPSON Printer Utility in your Applications folder. Select **SPro 4000**, and click **OK**.
  - **Mac OS 9.x:** Select **Print**, then click the  utility button in the print dialog box.
  - **Windows XP:** Click **Start** and select **Control Panel**. Double-click **Printers and Other Hardware**, then double-click **Printers and Faxes**. Right-click your printer icon and select **Printing Preferences**. Click the **Utility** tab.
  - **Other versions of Windows:** Click **Start**, point to **Settings**, then select **Printers**. Right-click your printer icon and select **Properties** (Windows 98 or Me), **Document Defaults** (Windows NT), or **Printing Preferences** (Windows 2000). Click the **Utility** tab.

You see a screen like the following:









3. Click the **Nozzle Check** icon.
4. Click **Auto** and follow the instructions on the screen.

The nozzle check pattern is printed and automatically read. If the printer finds clogged nozzles, it runs a cleaning cycle.

## Running a Power Cleaning Cycle

You can run a power cleaning cycle from the control panel if the normal cleaning process is not sufficient to clear the nozzles. However, the power cycle uses a large quantity of ink, so it is recommended only as a last resort.

The cartridges need to be at least 50% full to use power cleaning. You may need to replace a low cartridge to run the cleaning cycle. After cleaning, you can reinsert the old cartridge.

1. Print a nozzle check to make sure the print head needs cleaning, as described above.
2. Make sure no paper is loaded and the red  ink light on the printer's LCD panel is not on or flashing.
3. Press the Menu  button.
4. Press the  button until you see MAINTENANCE, then press Menu .
5. Press the  button until you see PWR CLEANING, then press Menu  to start the cleaning process.
6. Follow the instructions on the LCD panel to raise or lower the ink levers.
7. When cleaning is finished and the  Pause light stops flashing, print the nozzle check again to confirm that the head is clean.

**Caution:** Don't run a cleaning cycle while thick media is loaded in the printer.

**Note:** You must use at least a 10x eye loupe to check the pattern.

You may need to run the cleaning cycle several times to get a clean nozzle check pattern. For effective cleaning, always run a nozzle check between cycles.

If the lines in the pattern are still missing dots after several cleaning cycles, turn the printer off and leave it overnight, then clean the print head again the following morning. If you still see no improvement, contact EPSON for assistance.

## Aligning the Print Head

Aligning the print head is the most important thing you can do to ensure the best print quality. If banding appears on your prints, if they look grainy or blurry, or you see misregistration or “ghosting,” you need to align the print head.

Although you can align the print head using the printer utility software, it’s best to align from the control panel. This will do the most thorough job in the shortest time, and it’s all automatic.

If you haven’t already done so, it’s a good idea to run a nozzle check before aligning the print head (page 75). This ensures that the print head alignment patterns print correctly.

Follow these steps to align the print head using the control panel:

**Tip:** To properly align the print head, you must use EPSON Enhanced Matte paper.

1. Make sure the printer is turned on. Then load EPSON Enhanced Matte paper.
2. Press the **Menu** > button.
3. Press the **^** button so you see **HEAD ALIGNMENT**, then press **Menu** >. You see **PAPER THKNS**.
4. Press the **Menu** > button again so that **\*STD** appears on the display. This is the correct thickness setting for most EPSON papers, including Enhanced Matte paper.
5. Press the **Menu** > button to register the value, then press the **<** button to display **PAPER THKNS** again.
6. Press the **v** button to display **ALIGNMENT**.
7. Press the **Menu** > button to display **AUTO**, then press the **Menu** > button again. You see **UNI-D** (uni-directional). This is the type of alignment to start with.
8. Press the **Menu** > button again to start the alignment process.

It takes about 7 minutes to run the automatic uni-directional head alignment. The printer’s white beam sensor reads the alignment pattern and adjusts the printer automatically. Make sure you don’t open the top cover or turn off the printer during this process.

9. When the uni-directional alignment is finished, press the **^** button until you see **BI-D BLACK**. Then press the **Menu** **>⏏** button again to start the bi-directional black alignment process, which is also completely automatic and takes about 7 minutes.
10. When the bi-directional black alignment is finished, press the **^** button until you see **BI-D ALL**. Then press the **Menu** **>⏏** button again to start the alignment process. Again, this process is completely automatic and takes about 7 minutes.
11. When done, press the **||** Pause button to exit the head alignment mode.

If you want to verify or fine-tune the automatic alignment process, you can perform a manual head alignment. See your electronic *Reference Guide* for instructions.

**Tip:** You can store partially used ink cartridges for up to 6 months.

## Replacing Ink Cartridges

Before you begin a large print job, you should check your ink levels. If one of your cartridges is low, you can replace it before you start. Or you can wait until the ink runs out, replace the cartridge, and then continue the job without any loss of print quality.

The easiest way to check ink levels is from the control panel:

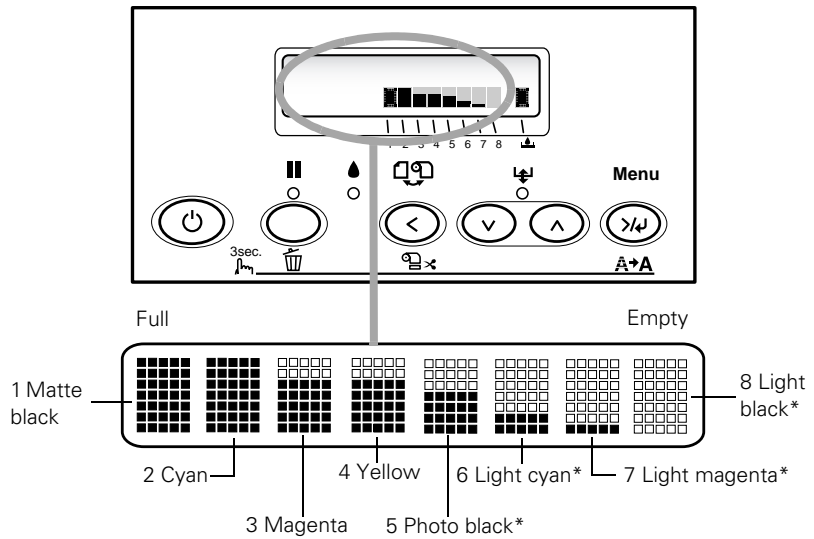

\* These are the cartridges used in the photographic mode. If your printer uses the dual CMYK mode, cartridges 5–8 will contain the same colors as cartridges 1–4.

When the red  ink light is flashing (and INK LOW is displayed on the LCD panel), the indicated cartridge is almost out of ink. Make sure you have a replacement cartridge. When the light stays on and INK OUT is displayed, the cartridge is empty. You must replace the cartridge before you can continue printing.

You can install any combination of 110 ml and 220 ml cartridges. It's a good idea to keep a set of empty 110 ml cartridges on hand at all times in case you need to ship the printer.

**Caution:** You must use the EPSON ink cartridges designed for your printer. Other ink cartridges will not work and may cause damage not covered by your warranty.

Use the following EPSON ink cartridges:

Cartridge	110 ml	220 ml*
Photo Black	T543100	T544100
Matte Black	T543800	T544800
Light Black	T543700	T544700
Cyan	T543200	T544200
Magenta	T543300	T544300
Light Magenta	T543600	T544600
Light Cyan	T543500	T544500
Yellow	T543400	T544400

\* When using these cartridges, you must leave the ink compartment door open.

To order EPSON ink cartridges, contact your dealer or call EPSON at (800) 873-7766. You can also order directly from the EPSON Store at [www.epsonstore.com](http://www.epsonstore.com) (U.S. only). In Canada, please call (800) 463-7766 for dealer referral.

**Caution:** Leave the empty cartridge in the printer until you are ready to replace it.

Before you start, make sure the printer is powered on. Then follow these steps to replace an ink cartridge:

1. Note the color of the cartridge whose light is on or flashing. This is the cartridge you need to replace.
2. Press the ink compartment cover to open it.

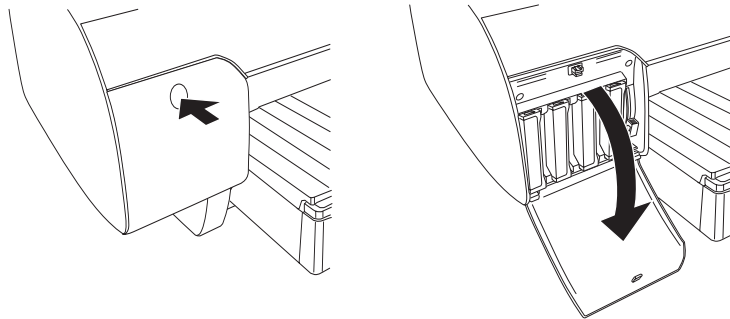

3. Raise the ink levers to the unlocked position.

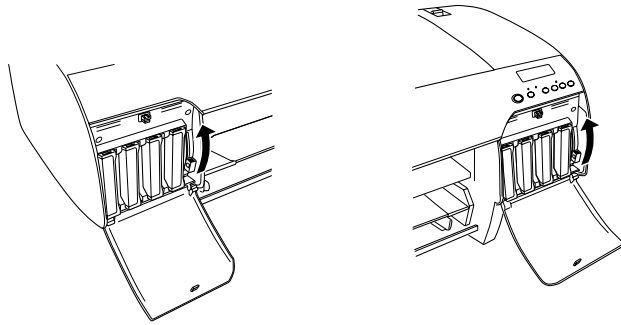

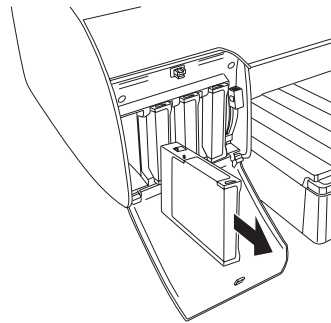

4. Remove the empty ink cartridge from the printer. Make sure you save your first set of empty 110 ml cartridges, so you can use them for transporting the printer.

Do not shake the empty cartridge, or ink may leak out. If ink gets on your hands, wash them thoroughly with soap and water. If ink gets in your eyes, flush them immediately with water.

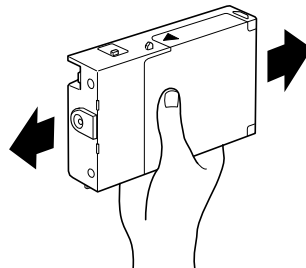

5. Make sure the replacement cartridge is the correct color, and remove it from its package.
6. Gently shake the cartridge before installing it.



**Note:** If you can't insert the cartridge smoothly, you may have the wrong cartridge. Check the package and product code. If the  ink light remains on after installing the cartridge, it may not be inserted fully.

7. Hold the cartridge with the arrow pointing toward the printer. Then insert the cartridge into the slot. Don't force it in.

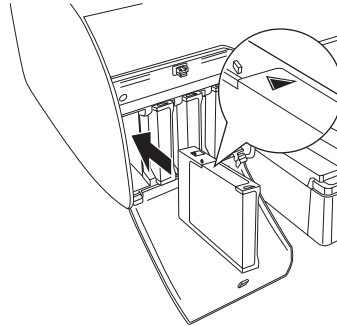

8. Lower the ink lever to its locked position.

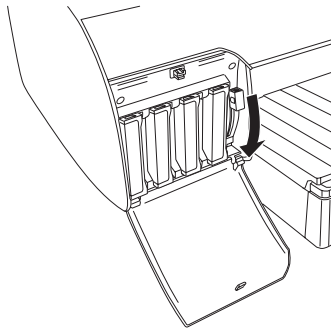

**Caution:** Do not remove and re-insert cartridges more often than necessary. Doing so can compromise the needle valve seal and allow air to enter the ink tubes, causing nozzle loss.

9. If you're using 110 ml cartridges, close the ink compartment cover. If you're using 220 ml cartridges, you'll have to leave the cover open.

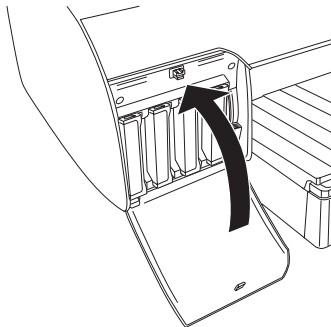

Once the cartridges are installed, the printer returns to its **READY** state.

## Using the Maintenance Mode

The maintenance mode allows you to make special settings and perform maintenance procedures that may be needed occasionally. You can use the maintenance mode to do the following:

- Print a hex dump for diagnosing problems
- Change the language or units of measurements used on the printer's control panel menus
- Change the default pressure setting for the automatic cutter
- Run a “supersonic” cleaning cycle.
- Return all of the printer's control panel settings to their default values

Follow these steps to use the maintenance mode:

1. Make sure the printer is turned off. Press and hold the **■** Pause button, then press the **⏻** Power button until the printer turns on and displays **HEX DUMP** on the LCD panel.
2. Press the **^** or **v** button to select the settings described below. If you need to back up to the previous menu level, press the **<** button.
  - To print a hex dump of data in the printer's buffer, press the **Menu >↵** button to display **EXEC**. Then press **Menu >↵** again to print the 16-byte hex data in the left column and corresponding ASCII characters in the right column. Press the **■** Pause button to print the last page.
  - To change the language displayed on the LCD panel, press the **v** button until you see **LANGUAGE**, then press the **Menu >↵** button. Press the **v** button until you see the language you want, then press **Menu >↵** again to select it. The printer exits maintenance mode and returns to normal operation.
  - To change the units of measurement, press the **v** button until you see **UNIT**, then press the **Menu >↵** button. Press the **v** button to switch from **METER** to **FEET/INCH**, then press **Menu >↵** to select the units you want.

- To change the default cutting pressure, press the **▼** button until you see **CUT PRESSURE**, then press the **Menu >↵** button to display **100%**. Press the **▼** button to decrease the pressure, or the **▲** button to increase it (in 1% increments). Press **Menu >↵** to select the setting you want.
  - To run a supersonic cleaning cycle, press the **▼** button until you see **SSCL**, then press the **Menu >↵** button to display **EXEC**. Press **Menu >↵** to start the cleaning cycle.
  - To return all control panel settings to their default values, press the **▲** button until you see **DEFAULT PANEL**, then press the **Menu >↵** button to display **EXEC**. Press **Menu >↵** again to restore the default settings.
3. To exit the maintenance mode, turn off the printer by pressing the **⏻** Power button. Press the **⏻** Power button again to turn on the printer in the normal operating mode.

**Note:** You can purchase replacement items for your printer from EPSON at (800) 873-7766, or by visiting the EPSON Store at [www.epsonstore.com](http://www.epsonstore.com) (U.S. sales only). In Canada, please call (800) 463-7766 for dealer referral.

## Replacing the Paper Cutter Blade

If you notice that your paper isn't cut cleanly, the cutter blade may need to be replaced. If you use the blade to cut heavy stock, you will damage the blade and need to replace it. See page 26 for a list of media that do not work with the cutter.

You can check the status of your cutter by printing the status check sheet or viewing its status on the control panel. See page 74 for instructions.

You can obtain a new cutter blade from EPSON (part number C12C815291).

Make sure the printer is on, then follow these steps to replace the blade:

1. Press the **Menu >↵** button.
2. Press the **▼** button until you see **MAINTENANCE**, then press **Menu >↵** again. You see **CUTTER REPL.**
3. Press **Menu >↵** to display **EXEC**.

**Caution:** Do not try to slide the carriage by hand, or you may damage the printer.

4. Press **Menu**  again. The print head moves to the replacement position. **OPEN TOP COVER** is displayed.
5. Open the top cover.

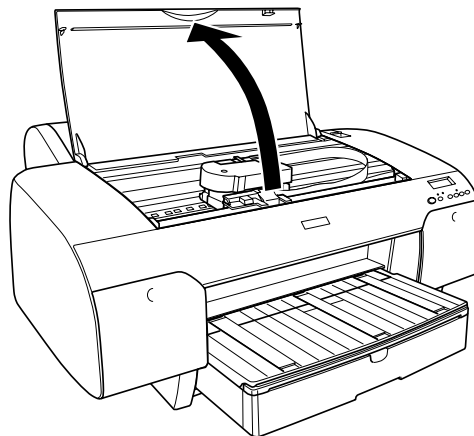

6. When **REPLACE CUTTER** is displayed on the LCD, hold down the side pin as shown and turn the latch to the right.

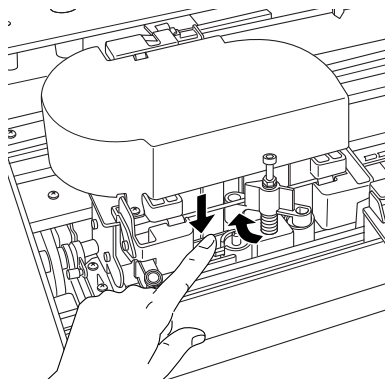

7. Release the side pin and carefully remove the cutter blade.

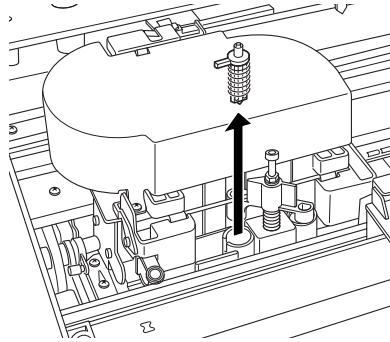

8. Insert the new cutter as shown.

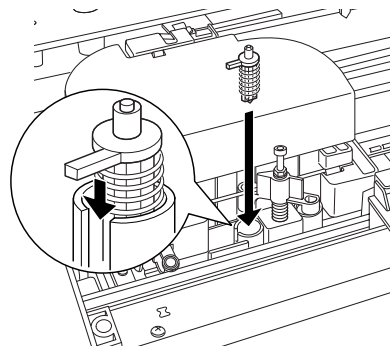

9. Push down on the side pin while turning the latch to the left.

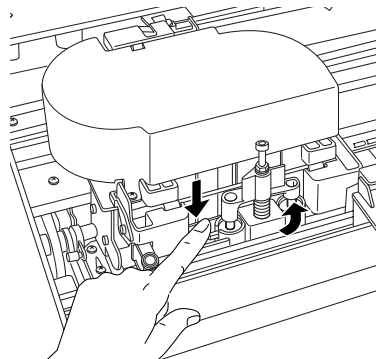

10. Close the top cover when you see a message prompting you to do so. The cutter moves to the home position.

## Replacing the Maintenance Tank

The maintenance tank stores ink that gets flushed from the system during automatic print head cleaning. When the tank is almost full, the message **MNT TK NEAR FULL** appears on the LCD panel. When the tank is completely full, the printer stops working and **MNT TK FULL** appears on the LCD.

You can check how much space remains in the maintenance tank by viewing its indicator on the control panel, shown below. You can also check its status using the SelecType menu (see page 74) or by printing a nozzle check sheet (see page 73).

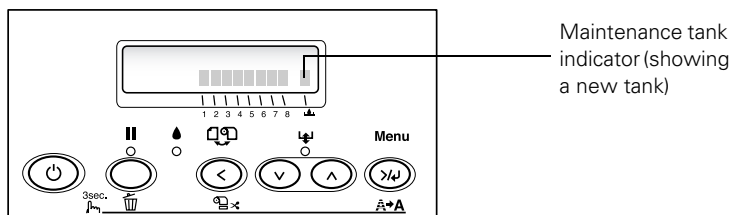

**Note:** You can purchase replacement items for your printer from EPSON at (800) 873-7766, or by visiting the EPSON Store at [www.epsonstore.com](http://www.epsonstore.com) (U.S. sales only). In Canada, please call (800) 463-7766 for dealer referral.

Replacement tanks are available from EPSON (part number C12C890071).

Follow these steps to replace the tank:

1. Make sure the printer is not printing or performing any other operations (**READY** or **PAPER OUT** should appear on the control panel).
2. If you are using 220 ml ink cartridges, remove the four cartridges from the right ink compartment, then close the compartment cover.

**Caution:** Be careful not to spill ink from the maintenance tank when removing it. Hold it upright at all times and dispose of it carefully.

3. Place your hand under the right ink compartment and gently pull out the maintenance tank.

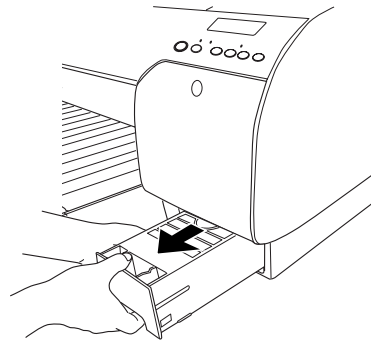

4. Place the used tank in the plastic bag included with the new tank.

5. Insert the new tank.

**Caution:** Be careful not to touch the gears inside the printer.

To avoid damaging the components as well as the case, never use alcohol or thinners to clean the printer.

Be careful not to get water on the printer mechanism or electronic components.

Don't use a hard or abrasive brush.

Don't spray the inside of the printer with lubricants; unsuitable oils can damage the mechanism. Contact your dealer or a qualified servicer if you think the printer needs lubrication.

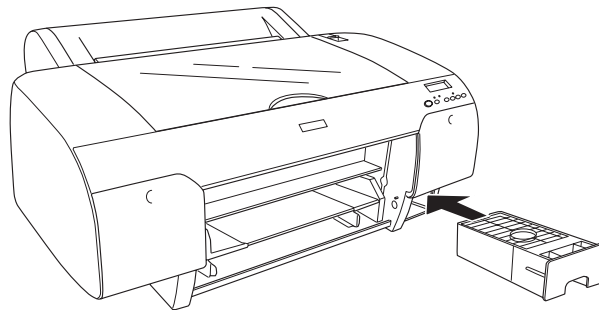

6. If you removed any ink cartridges, replace them after inserting the new maintenance tank.

## Cleaning the Printer

To keep your printer working at its best, you should clean it several times a year.

1. Make sure the printer is turned off and all its lights are off. Then unplug the power cord and disconnect the printer from your system.

2. Open the roll paper cover and remove the roll paper. Remove any sheets from the paper tray. Use a soft brush attachment to vacuum the paper tray.
3. If the paper path accidentally gets soiled with ink, gently clean it with a soft, lint-free cloth dampened with water.
4. If the outer case is dirty, clean it with a soft, clean cloth dampened with mild detergent. Keep the ink cartridge compartment closed to prevent water from getting inside.

## Transporting or Storing the Printer

If you are moving the printer a short distance (for example, in the same building), raise the ink levers and have at least two people lift the printer.

To ship the printer, you must repack it using the original box and packing materials and secure it to a pallet. If you do not have these items, contact EPSON to request them. Otherwise, the printer may be damaged beyond repair.

If your printer includes the EpsonNet Ethernet card, you should remove it before shipping the printer for repairs. See page 130 for instructions.

The printer weighs about 88

## Preparing the Printer for Shipment

1. Turn the printer on and remove the following parts:
  - All paper or other media
  - Roll paper spindle
  - Paper tray
2. If you are using the 110 ml ink cartridges, leave them installed. If you are using 220 ml cartridges, remove them and install 110 ml cartridges.

If you have the original cartridges that came with the printer (even if they are empty), install them before shipping the printer.

**Caution:** To avoid spilling ink and damaging the printer, you must leave the cartridges in place, raise the ink levers, and lock the print head.

To store partially used cartridges removed from the printer, tape over the needle valve hole and place each cartridge in a separate, resealable plastic bag. Be sure to remove the tape before reinstalling the cartridges. The printer must be powered on when removing or installing ink cartridges.

3. Raise the ink levers.

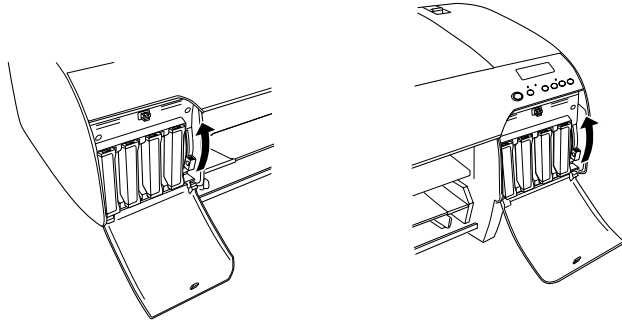

4. Make sure the print head is in the home (far right) position. Then lock the print head by pushing the green tab to the right.

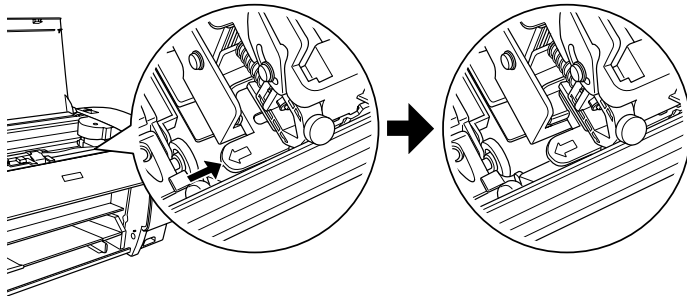

**Caution:** Do not turn off the printer by unplugging it or turning off a power strip. You will not be able to lock the print head, and ink will leak out of the reservoir, damaging the printer.

5. Turn off the printer and unplug the power cord.
6. If you need to ship the printer, you must repack it using the original box and packing materials and secure it to a pallet. If you do not have these items, contact EPSON to request them. Otherwise, the printer may be damaged beyond repair.

If you are transporting the printer in your own vehicle without the original packaging, make sure you wrap and pack the printer securely. Transport the printer in a horizontal position on a flat, stable surface.

7. Keep the printer level while moving it.

**Caution:** Make sure you release the print head by pulling out the green tab.

## Setting Up the Printer After Transportation

Setting up the printer after transporting it is almost identical to setting it up for the first time, as described on the *Start Here* sheet.

Keep in mind that the first time you start printing after moving the printer, the print head nozzles may be clogged—especially if the printer hasn't been turned on for a long time. You may need to run a cleaning cycle (page 75) and realign the print head (page 78) to ensure good print quality.

If you see the message **PERFORM POWER CLEANING?** on the LCD panel after setting up the printer, select **Y** to start the power cleaning process, as described on page 77.

## Uninstalling and Reinstalling the Printer Driver

If you need to uninstall and then reinstall the printer driver software for any reason, follow the instructions in the appropriate section below.

### Macintosh

1. Insert your printer software CD-ROM. Then double-click the CD-ROM icon to open it, if necessary.
2. Double-click the **Installer** program to open it.
3. Double-click **Install Printer Driver and Utilities**.
4. Enter your password if necessary.
5. Click **Continue** on the next screen.
6. Click **Accept** on the license agreement screen.
7. On the installer screen, click the arrow in the **Easy Install** list at the top and select **Uninstall**. Then click the **Uninstall** button at the bottom and follow the on-screen instructions.

8. If you want to reinstall your printer software, restart your Macintosh. Then follow the instructions on the *Start Here* sheet to install the software.

## Windows

1. On Windows XP, click **Start > Control Panel**.  
On other versions of Windows, double-click  **My Computer**, then double-click the **Control Panel** icon.
2. Double-click **Add/Remove Programs**. Click **EPSON Printer Software** in the program list, then select your printer icon.
3. Click the **Change/Remove** or **Add/Remove** button and follow the on-screen instructions.
4. If you're using the USB port in Windows 98 or Me, click **EPSON USB Printer Devices** in the program list; then click the **Add/Remove** button.
5. If you want to reinstall your printer software, restart your computer. Then follow the instructions on the *Start Here* sheet to install the software.



## Chapter 5: Solving Problems

As you use your printer, you may occasionally experience a problem. The first thing you should do is diagnose the problem following the guidelines in this chapter. Then try the most likely solutions until the problem is fixed.

This chapter provides instructions for the following:

- Diagnosing problems
- Checking error messages and lights
- Improving print quality
- Solving operational problems
- Solving miscellaneous printing problems
- Solving paper problems, including clearing paper jams

### Diagnosing Problems

The EPSON Stylus Pro 4000 includes a number of ways to help you diagnose problems:





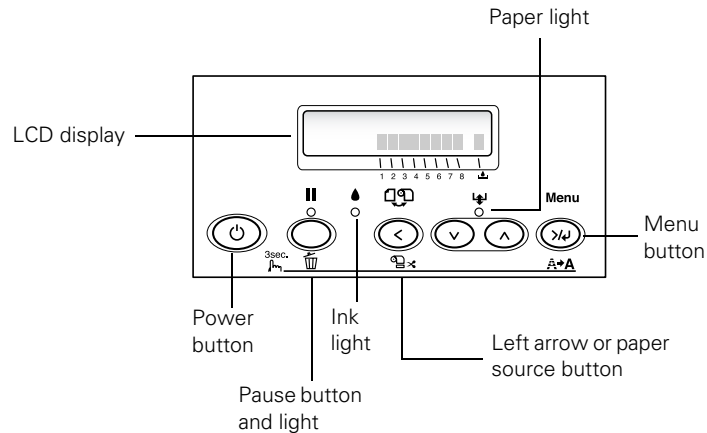

- To identify the most common problems, check the messages and lights on the control panel. See page 112 for more information.
- If you're using the EPSON printer driver and Status Monitor utility, check your software for error messages. See Chapter 3 or 4 for more information.
- To determine whether the problem is caused by the printer itself, disconnect the printer from your computer and run a nozzle check from the control panel. See page 73 for instructions.
- If none of the suggested solutions in this chapter solve your problem, contact EPSON as described under "Where To Get Help" on page 11.

## Checking Error Messages and Lights

The control panel includes various lights and an LCD display to indicate the status of the printer:







When your ink or paper runs out or a problem occurs, a message appears on the LCD display, and the lights on the control panel come on or flash. The following table lists the messages in alphabetical order and includes an explanation and instructions for correcting the problem.

Message	Light	Explanation	Response
CHANGE PAPER TYPE	 Paper light on	Paper loaded does not match the source selected.	Press the < Paper Source button to select the correct setting: either  (for paper in the tray, or  or  for roll paper).
COMMAND ERROR	—	You're using the wrong printer driver.	Press the  Pause button and hold it for 3 seconds to cancel the print job. Make sure you installed the correct driver for your printer.
		Damaged data was sent to the printer.	Press the  Pause button and hold it for 3 seconds to cancel the print job.
FEED SHEET PAPER	—	Cut sheet needs to be loaded manually.	Load the sheet in the manual feed slot. See page 35 for instructions.
FEED SHEET PAPER MANUALLY	—		
FORBIDDEN MEDIA FROM P. TRAY	—	Cut sheet needs to be loaded manually.	Load the sheet in the manual feed slot. See page 35 for instructions.

Message	Light	Explanation	Response
INK LOW	● Ink light flashing	Ink cartridge(s) are nearly empty (printing continues).	Make sure you have replacement cartridges available. See page 79.
INK OUT	● Ink light on	Ink cartridge(s) are empty (printing stops).	Replace the ink cartridge(s) indicated on the LCD panel. See page 79 for instructions.
INVALID INK CARTRIDGE	● Ink light on	You tried to install the wrong ink cartridge.	If you are installing ink cartridges for the first time, you must install the cartridges that came with your printer.  If you are replacing ink cartridges, check the package and product code. You must use the ink cartridges designed for your printer. Other cartridges will not work.
LOAD PAPER	👉 Paper light on	Paper lever is in the released position while loading paper.	After you finish loading paper, pull the paper lever all the way forward, to the secured position.
LOAD ROLL PAPER LOAD SHEET PAPER IN P. TRAY	👉 Paper light on	Paper source setting in printer software is different from control panel.	Make sure the right paper is loaded and the paper source setting is the same on the control panel and printer software.
LOWER INK LEVERS LOWER L (or R) INK LEVER	—	One or both ink levers are raised.	Pull the lever or levers down to lock the ink cartridges.
MNT REQ.	—	A printer part will need to be replaced soon.	Note the code number and contact EPSON as described on page 11.
MNT TNK NEAR FULL	—	The maintenance tank is almost full.	Make sure you have a replacement maintenance tank. See page 88.
MNT TNK FULL	● Ink light on	The maintenance tank is full.	Replace the maintenance tank. See page 88 for instructions.
NO BORDERLESS WITH THIS SIZE	—	Borderless setting selected for A2-size sheets (11.7 × 16.5)	Change the setting in the printer driver, or load different-size paper.
NO MNT TNK	—	The maintenance tank is not installed.	Make sure the maintenance tank is fully inserted. See page 88 for instructions.
NOT STRAIGHT RELOAD	👉 Paper light on	Cut sheet paper is not loaded straight.	Load the paper correctly.

Message	Light	Explanation	Response
NOZZLES STILL CLOGGED	—	Head cleaning did not clear the nozzles.	Run the head cleaning utility again. If the nozzles are still clogged, contact EPSON.
OPTION I/F ERROR	—	Wrong interface card installed.	Turn off the printer and remove the card. See the documentation that came with the card.
NO INK CARTRIDGE	💧 Ink light on	Ink cartridge(s) not installed or ink lever raised.	Install ink cartridges (page 79) or lower the ink lever.
PAPER JAM	📄 Paper light flashing	Paper has jammed in the printer.	Remove the jammed paper. See page 123 for more information.
PAPER NOT CUT	📄 Paper light flashing	Roll paper was not cut correctly.	Open the top cover and remove the uncut paper. Reload paper if necessary.
		The cutter may be blunt or incorrectly installed.	Reinstall or replace the cutter blade if necessary, as described on page 85.
PAPER NOT STRAIGHT	📄 Paper light flashing	Paper slipped and fed into the printer at an angle.	Reload paper, making sure the edges are straight.
PAPER OUT	📄 Paper light on	No paper is loaded.	Load paper.
		Paper ran out.	Remove any printouts or paper remaining in the printer and load more paper.  If the message appears during a print job, reset the printer by pressing the <b>Pause</b> button for 3 seconds. Then load paper and resend the job.
REAR COVER OPEN	—	The rear cover has been removed.	Replace the rear cover.
RELOAD PAPER	📄 Paper light on	Printer cannot detect paper.	If you are using cut sheets, make sure the paper is flat. Move the paper lever.
		<b>PAPER NOT CUT</b> error was cleared.	Reload paper.
RELOAD PAPER INSERT DEEPLY	📄 Paper light on	Manually loaded sheet is not inserted far enough.	Insert the sheet further into the printer. See page 35 for instructions.
REMOVE PAPER	📄 Paper light on	Paper is too thick for head cleaning.	Pull the paper lever out to remove the paper. Head cleaning automatically starts. After cleaning, reload paper.
		Printer could not feed the printed page.	Remove the print.

Message	Light	Explanation	Response
SERVICE REQ.	All lights flashing	The print head is locked.	Pull out the green tab to unlock the print head. See page 90.
		An error has occurred.	Note the error number, then turn the printer off and back on. If the message remains, contact EPSON as described on page 11.
SET INK CRTG	—	Ink cartridge chip error.	Remove and reinstall the ink cartridge. If the message remains, replace the cartridge.
SET PAPER LEVER	 Paper light on	Paper lever was released during the printing process or another operation.	Pull the lever all the way forward, to the secured position. Start printing again from the beginning for best results.
TOP COVER OPEN	—	Top cover is open.	Close the top cover.
UNABLE TO PRINT	—	You tried to print while an error condition was present.	Press the  Pause button to exit the SelecType menu system. If the message appears again, clear the error before you print.
WRONG INK CARTRIDGE	 Ink light on	You tried to install the wrong ink cartridge.	If you are installing ink cartridges for the first time, you must install the cartridges that came with your printer.
			If you are replacing ink cartridges, check the package and product code. You must use the ink cartridges designed for your printer. Other cartridges will not work.
WRONG PAPER SIZE	 Paper light flashing	Loaded paper does not match the image size.	Make sure the size you selected in the printer driver matches the loaded paper size. Load the correct size paper if necessary.

## Improving Print Quality

You can often improve print quality by doing the following:

- Run a nozzle check and cleaning cycle. See page 75 for instructions.
- Align the print head. See page 78 for instructions.
- When you send a print job, make sure your print options are set correctly. For more information, see Chapter 3 (Macintosh) or 4 (Windows).

If none of these suggestions help, try the solutions below.

Problem	Solution
Your print has horizontal banding.	<ul style="list-style-type: none"> <li>▶ Check the ink indicators and light to see if you are low on ink. Replace ink cartridges if necessary, as described on page 79.</li> <li>▶ Run a nozzle check and cleaning cycle. See page 75 for instructions.</li> <li>▶ Align the print head from the printer's control panel, as described on page 78.</li> <li>▶ Turn off <b>High Speed</b> in your Advanced settings.</li> <li>▶ Make sure the <b>Media Type</b> setting in the printer software is correct for the media you're printing on.</li> <li>▶ If you're using cut sheet media, make sure the printable side is face down in the tray.</li> <li>▶ Choose a higher resolution, such as <b>SuperPhoto - 2880dpi</b>.</li> <li>▶ If you're using a third-party RIP and non-EPSON media, see if the RIP provides a method for adjusting the paper feed.</li> </ul> <p>Try adjusting your paper configuration settings (page 51 for Mac OS X, page 66 for Mac OS 9, or page 83 for Windows). Check these settings:</p> <ul style="list-style-type: none"> <li>▶ Make sure the <b>Paper Thickness</b> setting is correct for the paper you're printing on.</li> <li>▶ If you're printing on thin paper that's getting saturated with ink, reduce the <b>Paper Suction</b>.</li> <li>▶ Use the <b>Paper Feed Adjustment</b> to tune out banding. Reduce the value for white lines, and increase it for overlapping dark lines.</li> <li>▶ If you've created a custom paper configuration, be sure to return the setting to standard (<b>STD</b>) when you're done using it. See page 40.</li> </ul>

Problem	Solution
Your print is grainy, or has misregistration or ghosting.	<ul style="list-style-type: none"> <li>▶ Check the ink indicators and light to see if you are low on ink. Replace ink cartridges if necessary, as described on page 79.</li> <li>▶ Run a nozzle check and cleaning cycle. See page 75 for instructions.</li> <li>▶ Align the print head, as described on page 78.</li> <li>▶ Make sure the <b>Media Type</b> setting in the printer software is correct for the media you're printing on.</li> </ul> <hr/> <ul style="list-style-type: none"> <li>▶ If you're using cut sheet media, make sure the printable side is face down in the tray.</li> <li>▶ Choose a higher resolution, such as 2880 dpi.</li> <li>▶ Turn off <b>High Speed</b> in your Advanced settings.</li> </ul> <p>You may need to adjust your paper configuration settings (page 51 for Mac OS X, page 66 for Mac OS 9, or page 83 for Windows). Check these settings:</p> <ul style="list-style-type: none"> <li>▶ Make sure <b>Paper Thickness</b> setting is correct for the paper you're printing on.</li> <li>▶ If you've created a custom paper configuration, be sure to return the setting to standard (<b>STD</b>) when you're done using it. See page 40.</li> </ul>
Colors are incorrect or missing.	<ul style="list-style-type: none"> <li>▶ Make sure the <b>Media Type</b> setting in the printer software is correct for the media you're printing on.</li> <li>▶ If you are using the color management features in Photoshop or another application, you must turn off color management in the printer driver. See page 50 (Mac OS X) page 65 (Mac OS 9), or page 82 (Windows).</li> <li>▶ Adjust the <b>Color Density</b> setting in the Paper Configuration utility.</li> <li>▶ If you're using a third-party RIP or non-EPSON media, custom color profiles will give you the best color reproduction.</li> <li>▶ If you're using cut sheet media, make sure the printable side is face down in the tray.</li> <li>▶ Run a nozzle check and cleaning cycle (see page 75).</li> <li>▶ Check the expiration date printed on each of the ink cartridges. If the cartridge is too old, replace it as described on page 79.</li> <li>▶ Check the ink indicators and light, and replace ink cartridges if your ink supply is low, as described on page 79.</li> <li>▶ Make sure color settings in your application or printer software are correct.</li> </ul>

Problem	Solution
Your print has gaps or appears faint.	<ul style="list-style-type: none"> <li>▶ Check the expiration date printed on each of the ink cartridges. If the cartridge is too old, replace it as described on page 79.</li> <li>▶ Make sure the <b>Media Type</b> setting in the printer software is correct for the media you're printing on.</li> <li>▶ Run a nozzle check and cleaning cycle (see page 75).</li> <li>▶ Check the ink indicators and light and replace ink cartridges if your ink supply is low, as described on page 79.</li> <li>▶ The paper thickness setting is not correct for the paper you're printing on. Use your printer software (page 51 for Mac OS X, page 66 for Mac OS 9, or page 83 for Windows) to choose the correct setting. When you're done printing with a custom paper configuration, be sure to return the setting to standard (<b>STD</b>).</li> <li>▶ The platen gap setting is too wide. Use the Menu system to change the setting to <b>STANDARD</b>, or to <b>NARROW</b> if printing on very thin paper. See page 39 for instructions.</li> </ul>
Your print appears blurry or smeared.	<ul style="list-style-type: none"> <li>▶ Make sure the <b>Media Type</b> setting in the printer software is correct for the media you're printing on.</li> <li>▶ If you're printing on non-EPSON media, you may need to adjust the paper thickness setting, drying time, or color density. Use your printer software (page 51 for Mac OS X, page 66 for Mac OS 9, or page 83 for Windows) to choose the correct setting. When you're done printing with a custom paper configuration, be sure to return the setting to standard (<b>STD</b>).</li> <li>▶ Your paper doesn't meet the required specifications or wasn't stored in a dry, humidity-free environment. Load new paper.</li> <li>▶ If you're using cut sheet media, make sure the printable side is face down in the tray.</li> <li>▶ Ink has leaked into the paper path. Wipe the paper path area of the printer with a soft, clean cloth. See page 89 for cleaning instructions.</li> <li>▶ Turn off <b>High Speed</b> in your Advanced settings.</li> <li>▶ The platen gap setting is too narrow. Use the control panel to change the setting to <b>WIDE</b> or <b>WIDER</b>. See page 39 for instructions.</li> <li>▶ Run a nozzle check and cleaning cycle (see page 75).</li> </ul>

Problem	Solution
The bottom edge of your print is smeared.	<ul style="list-style-type: none"> <li>▶ The paper is curled toward the printable side. Flatten the paper or curl it toward the other side.</li> <li>▶ Make sure the <b>Media Type</b> setting in your printer software is correct for the media you're printing on.</li> <li>▶ If you're printing on non-EPSON media, you may need to adjust the paper thickness setting or drying time. Use your printer software (page 51 for Mac OS X, page 66 for Mac OS 9, or page 83 for Windows) to choose the correct setting. When you're done printing with a custom paper configuration, be sure to return the setting to standard (STD).</li> <li>▶ If printing on thick paper, the platen gap setting may be incorrect. Use the control panel to change the setting to <b>WIDE</b> or <b>WIDER</b>. See page 39 for instructions.</li> </ul>

## Solving Operational Problems

If you can't turn the printer on, if it stops printing unexpectedly, or if nothing prints, check the following:

- The printer is turned on.
- Paper is loaded in the printer.
- The printer is plugged securely into a working electrical outlet that's not controlled by a switch or timer.
- The interface cable is securely connected to the printer and your system.
- The voltage supplied by the electrical outlet matches the voltage on the printer's rating label. If not, turn off the power and unplug the power cord immediately. Contact EPSON for assistance. (See page 11 for details.)

If none of these suggestions help, try the solutions on the following page.

Problem	Solution
The printer stops printing unexpectedly.	<ul style="list-style-type: none"> <li>▶ If the <b>   </b> Pause light is flashing, the printer is performing a maintenance procedure or waiting for ink to dry. Check the display message and lights on the control panel. Wait until the <b>   </b> Pause light stops flashing.</li> <li>▶ Check the display message and lights on the control panel to see if an error has occurred. Follow the instructions for the messages beginning on page 112.</li> </ul>
The printer sounds as if it's printing, but nothing prints.	<ul style="list-style-type: none"> <li>▶ Follow the instructions beginning on page 75 to clean the print head.</li> <li>▶ Communication between the computer and printer may have been momentarily interrupted. Try restarting the computer and printing again.</li> </ul>
Nothing prints.	<ul style="list-style-type: none"> <li>▶ Turn off the printer and computer. Make sure the interface cable is securely plugged in. Then restart the printer and computer.</li> <li>▶ Make sure the interface cable meets the required specifications. See page 11 or 12.</li> <li>▶ Make sure the interface cable is directly connected to the computer without passing through a printer switching device, Zip™ drive, or extension cable.</li> <li>▶ The printer port setting doesn't match the printer connection port (Windows). <ul style="list-style-type: none"> <li><b>Windows Me or 98:</b> Click <b>Start &gt; Settings &gt; Printers</b>. Right-click the icon for your printer, then select <b>Properties</b>. Click the <b>Details</b> tab. Make sure your printer driver is selected in the <b>Print using the following driver</b> list. Then select the port to which your printer is connected in the <b>Print to the following port</b> list.</li> <li><b>Windows XP:</b> Click <b>Start Control &gt; Panel &gt; Printers and Other Hardware &gt; Printers and Faxes</b>. Right-click the icon for your printer, then select <b>Properties</b>. Click the <b>Ports</b> tab and make sure your printer port is selected.</li> <li><b>Windows 2000 or NT 4.0:</b> Click <b>Start &gt; Settings &gt; Printers</b>. Right-click the icon for your printer, then select <b>Properties</b>. Click the <b>Ports</b> tab and make sure your printer port is selected.</li> </ul> </li> <li>▶ The printer driver doesn't have enough available memory (Macintosh). Quit all unnecessary applications. To increase the available memory in your Macintosh, select <b>Control Panel</b> from the Apple menu and double-click the <b>Memory</b> icon (Mac OS 9). You can increase the size of virtual memory to increase total available memory.</li> <li>▶ Follow the instructions beginning on page 92 to uninstall your printer software. Then locate your printer software CD-ROM and reinstall the software.</li> </ul>

## Solving Miscellaneous Printing Problems

If your printouts are not what you expected, try the suggestions below:

Problem	Solution
Your print has incorrect or garbled characters.	<ul style="list-style-type: none"> <li>▶ Make sure your software is installed correctly and the printer is selected.</li> <li>▶ Clear any stalled print jobs from the Print Center (Mac OS X) Monitor IV (Mac OS 9) or Spool Manager (Windows 98 or Me).</li> <li>▶ Turn off the printer and computer. Make sure the interface cable is securely plugged in at both ends.</li> </ul>
Your print has incorrect margins.	<ul style="list-style-type: none"> <li>▶ Check the page size or paper size settings in your application. Make sure they are within the printer's printable area.</li> <li>▶ Make sure the <b>Paper Size</b> and <b>Borderless</b> settings in your printer software are correct for the paper you're using.</li> <li>▶ Paper is loaded incorrectly. Follow the instructions in Chapter 1 to reload the paper.</li> <li>▶ The <b>PAPER MARGIN</b> (roll paper margin) setting on the PRINTER SETUP menu is incorrect. If you're using roll paper, check the setting for <b>PAPER MARGIN</b>. See the on-screen <i>SP 4000 Reference Guide</i> for more information.</li> </ul>
Your image is inverted.	<ul style="list-style-type: none"> <li>▶ Turn off the <b>Flip Horizontal</b> setting in your printer software. See page 49 (Mac OS X) page 65 (Mac OS 9) or page 81 (Windows) for instructions.</li> </ul>
Blank paper is printed.	<ul style="list-style-type: none"> <li>▶ Make sure your software is installed correctly and the printer is selected.</li> <li>▶ Make sure the <b>Paper Size</b> setting in your printer software is correct for the paper you're using.</li> <li>▶ Make sure the <b>Paper Source</b> setting in your printer software is correct.</li> </ul>
A ruled line on your print appears to shift.	<ul style="list-style-type: none"> <li>▶ Align the print head as described on page 78.</li> </ul>
Color images print in black only.	<ul style="list-style-type: none"> <li>▶ Make sure <b>Color/B&amp;W Photo</b> is selected in your printer software.</li> </ul>
The printer continues to feed paper after you have cancelled a job.	<ul style="list-style-type: none"> <li>▶ Press the <b>   </b> Pause button on the printer to clear any print job data in the printer's buffer. Then press and hold the <b>   </b> Pause button to reset the printer.</li> </ul>
Roll paper cannot be cut.	<ul style="list-style-type: none"> <li>▶ The paper cutter blade may be dull. Follow the instructions on page 85 to replace the blade.</li> <li>▶ The paper may be too thick to cut with the built-in cutter. Cut the paper with scissors. See page 26 for a list of media that cannot be used with the cutter.</li> <li>▶ Make sure  appears on the LCD panel. If not, press the &lt; Paper Source button to select this setting.</li> </ul>

Problem	Solution
Printing is too slow.	<ul style="list-style-type: none"> <li>▶ Turn on <b>High Speed</b> in your Advanced settings.</li> <li>▶ Choose a lower resolution in your printer software for faster printing.</li> <li>▶ Clear space on your hard drive or run a defragmentation utility.</li> <li>▶ Don't run too many applications at the same time.</li> <li>▶ Turn off virtual memory.</li> <li>▶ Add RAM to your system.</li> <li>▶ If you're using Macintosh, turn off background printing. If you want to continue using background printing, select <b>EPSON Monitor IV</b> (Mac OS 9) and increase its memory requirements.</li> <li>▶ Consider upgrading your system to support a faster connection to the printer: either IEEE 1394 FireWire or USB 2.0.</li> </ul>

## Solving Paper Problems

If paper feed or paper jam problems occur frequently, try one or more of the following solutions:

- For roll paper, try adjusting the paper suction setting. See page 40 for more information. You can also adjust this setting through your printer driver.
- For heavy or thick media, follow the instructions on page 35 to load the media correctly.
- Make sure the paper is not folded, wrinkled, or damp.
- Make sure the printer's environment falls within the required temperature and humidity range.
- Make sure the paper is not too thick or too thin. See pages 17 and 133 to 134 for paper specifications.
- Make sure no foreign objects are inside the paper path.
- Make sure the printer isn't located in a brightly lit area. The paper sensors may not operate correctly.
- Make sure the **Media Type** and **Paper Source** settings in the printer software are correct.

- Make sure the platen gap setting is correct for the paper or media you're printing on. See page 39 for more information.
- If you're not using EPSON media, make sure you use a paper configuration to adjust for the paper's thickness and drying time (see page 40).
- If roll paper is curled tightly, select **Starwheel-Roll Curled** as the Feed Roller Type in your paper configuration settings.

## Clearing Roll Paper Jams

When roll paper gets jammed in the printer, printing stops and you see a **PAPER JAM** message on the LCD display. Follow these steps to clear a paper jam:

**Caution:** To avoid damaging the printer, never move the paper lever while the **Pause** light is flashing.

1. Turn off the printer, open the roll paper cover, and release the paper lever.

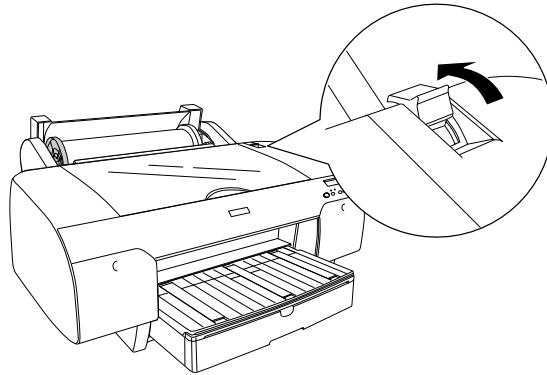

2. Cut the paper at the paper insertion slot, and remove the roll paper.

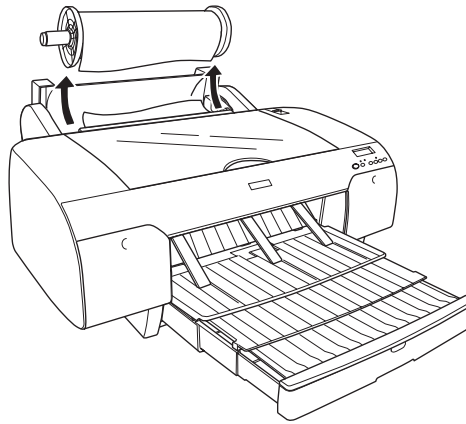

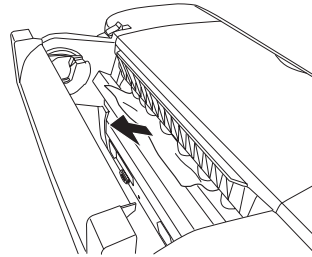

3. Remove the jammed paper from the front or back of the printer.

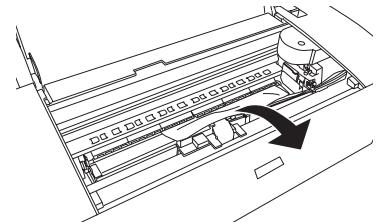
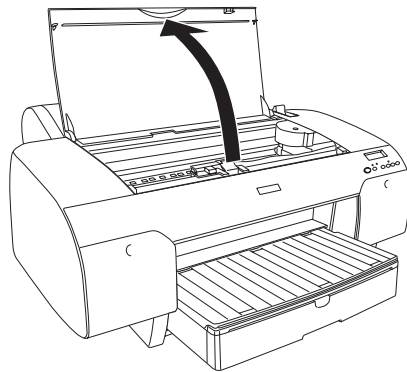

**Caution:** Be careful not to damage the print head when you pull out the paper.

4. If necessary, open the top cover and remove the jammed paper.



5. Make sure the  paper light is on and LOAD PAPER is displayed on the LCD panel. Then reload your paper.

## Clearing Paper Tray Jams

If paper gets jammed while feeding from the tray, follow these steps to clear it:

1. Turn off the printer and release the paper lever.

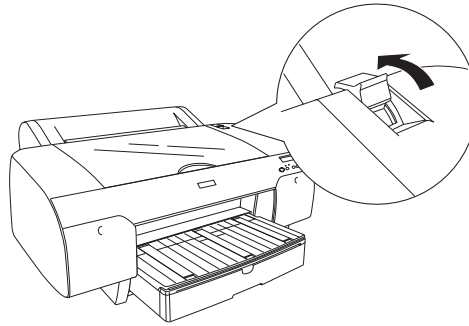

2. Remove the paper tray.

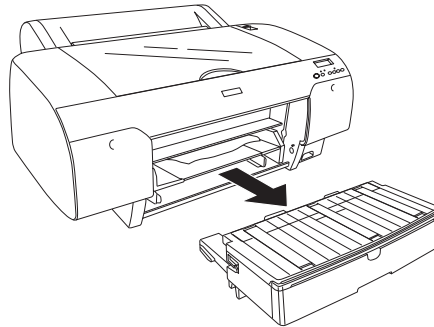

3. Carefully pull out the jammed paper.

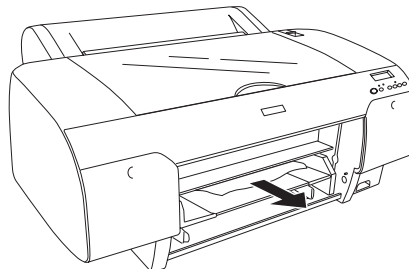

4. If paper is still jammed in the printer, open the top cover and remove it.

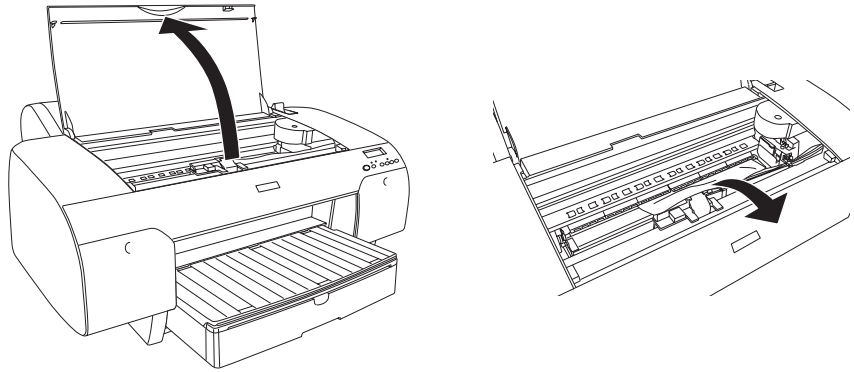

5. If paper is jammed around the rear cover, remove the cover by squeezing the square knobs and pulling the cover off the printer.

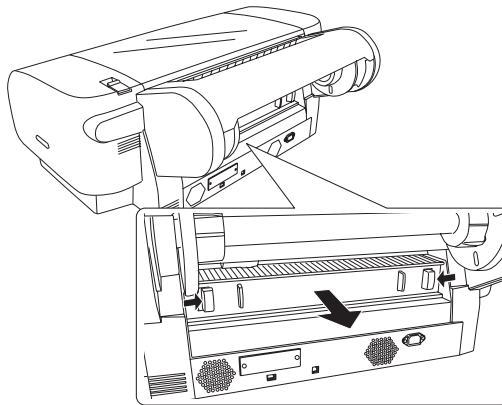

6. Then remove the paper.

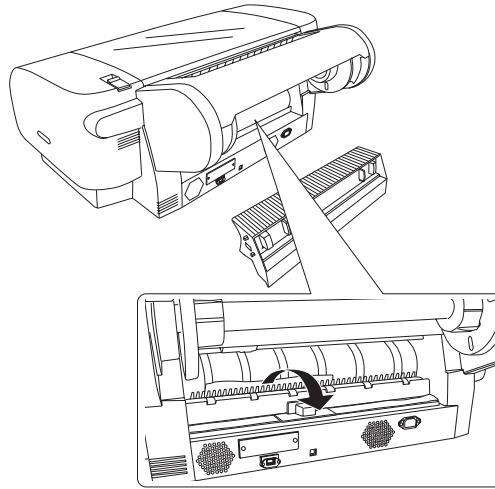

7. Reinstall the rear cover. Then press and hold the **||** Pause button if necessary to reset the printer.

## Clearing Paper Jams from the Manual Feed Slots

If paper is jammed in the front or rear manual feed slots, follow these steps to clear it:

1. Turn off the printer and release the paper lever.

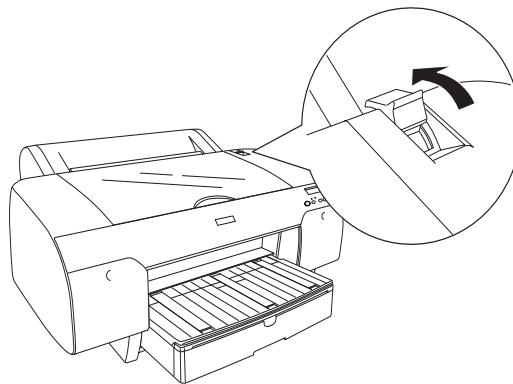

2. Remove the paper tray.

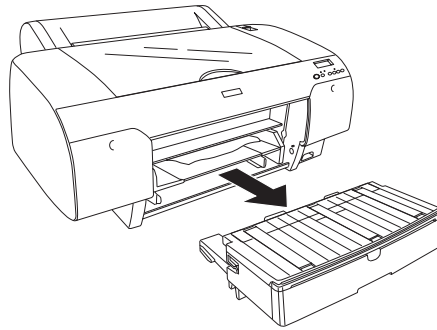

3. Carefully pull out the jammed paper.

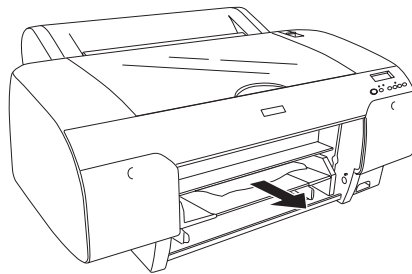

4. If you can't reach the paper from the front, remove it from the back of the printer.

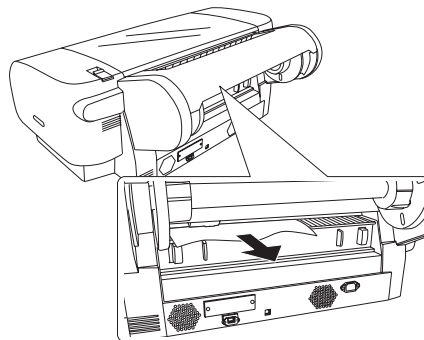

5. Press and hold the **||** Pause button if necessary to reset the printer.

## Appendix A: Installing the Optional Print Server Card

If your printer did not come with the optional EpsonNet print server card installed, you can install it yourself. The EpsonNet print server is a 10/100 Base TX Type B Ethernet interface card (part number C12C82405).

You can purchase the print server card and other optional equipment and supplies from EPSON at (800) 873-7766, or you can visit the EPSON Store at [www.epsonstore.com](http://www.epsonstore.com) (U.S. sales only). In Canada, please call (800) 463-7766 for dealer referral.

Make sure you have the correct cable for connecting the printer. To connect to a network hub, you need a standard RJ-45 “straight-through” network cable. To connect directly to your computer’s network interface, you need an RJ-45 crossover cable.

Before you install the print server, make sure you check the documentation included with the card for additional instructions. Then follow these steps to install the card:

**Caution:** You *must* unplug the printer from the power outlet, or you may damage the printer and the card.

1. Turn off your computer and printer.
2. **IMPORTANT:** Unplug the printer from its electrical outlet. Not doing so may cause damage to the printer and the card.
3. Disconnect any interface cables from the printer.
4. Use a cross-head screwdriver to remove the two screws securing the optional interface cover. Then lift off the cover as shown:

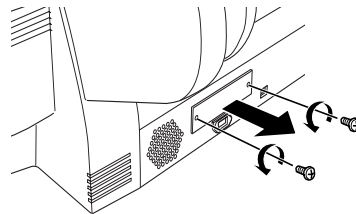

Make sure you keep the screws in case you need to remove the card and replace the cover.

5. Slide the card along the slots inside the compartment. Push it in firmly to fully insert the connector into the printer's internal slot.

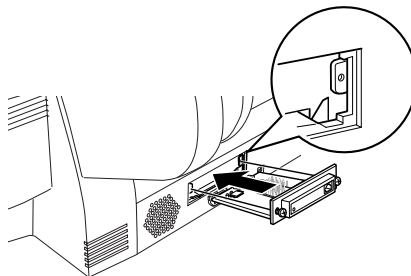

6. Use the two screws included with the card to secure it.
7. Connect one end of the appropriate cable to the card. Then connect the other end to your computer's Ethernet port or hub.
8. Plug in the printer's power cord.

Once the printer is connected to your network, you need to configure it. Turn on the printer and press the small black button on the back of the Ethernet card. Hold it down until the printer starts printing a series of status sheets. See the documentation that came with the print server for instructions on configuring it for your network.

## Removing the Print Server Card

**WARNING:** The card will be hot after printing. Make sure you allow the card to cool before handling it.

If you need to ship your printer to EPSON for service, you must remove the card.

1. Turn off the printer and disconnect the power cord.
2. Disconnect the Ethernet cable.
3. Remove the two screws securing the card.
4. Make sure the card is cool before pulling it out of the slot.

## Appendix B: Specifications

### Printing

Printing method	On-demand ink jet
Nozzle configuration	<p><b>Photo ink set:</b>            Black: 180 nozzles × 3 (photo black, matte black, light black)            Color: 180 nozzles × 5 (cyan, magenta, light cyan, light magenta, yellow)</p> <p><b>High Speed ink set:</b>            Matte black: 180 nozzles × 2            Color: 180 nozzles × 6 (2 cyan, 2 magenta, 2 yellow)</p>
Maximum resolution	2880 × 1440 dpi
Engine reliability	
Total print volume	20,000 A2 images (360 × 360 dpi)
Print head life	8.4 billion dots per nozzle
Periodic maintenance (pump unit, head cleaner, cap assembly)	Requires replacement approximately every 18,000 pages (A1-size plain paper)
Cutter blade life (user replaceable)	Approximately 2,000 B0+ sheets (EPSON media up to 4.33 mil thick); approximately 1,000 B0+ coated sheets
Print direction	Unidirectional/Bidirectional
Control code	EPSON ESC/P® Raster Photographic Driver
Paper feed speed	215 ± 10 milliseconds per 1/6-inch line
Line spacing	1/6 inch or programmable in 1/1440-inch increments
RAM	32MB

**Note:** Additional specifications are provided in the *Reference Guide* included on the CD-ROM that came with your printer.

## Environmental

	Operation	Storage	Transit (stored in shipping container)
Temperature	50 to 95 °F (10 to 35 °C)  Print quality guarantee: 59 to 77°F (15 to 25 °C)	-4 to 104 °F (-20 to 40 °C)  (1 month at 104 °F)	-4 to 140 °F (-20 to 60 °C)  (120 hours at 140 °F)
Humidity (without condensation)	20 to 80% RH  40 to 60% RH for guaranteed print quality	20 to 85% RH	5 to 85% RH

## Electrical

Specification	Description
Input voltage range	90 V to 264 V
Rated frequency range	50 to 60 Hz
Input frequency range	49 to 61 Hz
Rated current	1.0 A at 120 V 0.5 A at 220 V
Power consumption	Approx. 50 W or less (ISO 10561 letter pattern) 15 W or less in standby mode .7 W or less in power off mode

Check the label on the back of your printer for voltage information.

## Dimensions and Weight

<b>Height</b>	14.8 inches (369 mm)
<b>Width</b>	33.9 inches (848 mm)
<b>Depth</b>	30.5 inches (762 mm)
<b>Weight</b>	Approximately 88 lb (40 kg), without ink or paper



## Cut Sheets

<b>Sizes</b>	8 × 10 inches
	A4 (8.3 × 11.7 inches)
	Letter (8.5 × 11 inches)
	B4 (10.1 × 14.2 inches)
	11 × 14 inches
	30 × 40 cm (11.8 × 15.7 inches)
	A3 (11.7 × 16.5 inches)
	US B (11 × 17 inches)
	Super A3/B (13 × 19 inches)
	B3 (14.2 × 20.3 inches)
	16 × 20 inches
	40 × 60 cm (15.7 × 23.6 inches)
	A2 (16.5 × 23.4 inches)
	US C (17 × 22 inches)
<b>Weight range</b>	17 lb bond up to 1.5 mm posterboard

Since the quality of any particular brand or type of paper may be changed by the manufacturer at any time, EPSON cannot attest to the quality of any non-EPSON brand or type of paper. Always test samples of paper stock before purchasing large quantities or printing large jobs.

Poor quality paper may reduce print quality and cause paper jams or other problems. If you encounter problems, switch to a higher grade of paper. Do not use curled, folded, or deckle-edge paper.

## Printable Area

Default roll paper margins are 0.55 inches (15 mm) top and bottom, and 0.12 inches (3 mm) right and left. Using the Menu system, you can set all the margins to 15 mm or 3 mm.

Default cut sheet margins are 0.12 inch (3 mm) top, right, and left, and 0.55 inch (14 mm) bottom.

The borderless printing feature allows edge-to-edge printing on some media.

## Ink Cartridges

<b>Lightfastness*</b>	Color: up to 100 years Black and white: over 100 years
<b>Cartridge life</b>	2 years from production date if unopened; within 6 months after opening package, at 77 °F (25 °C)
<b>Temperature</b>	
Storage (uninstalled)	-22 to 104 °F (-30 to 40 °C); 1 month at 104 °F
Storage (installed)	-4 to 104 °F (-20 to 40 °C); 1 month at 104 °F
Transit	-22 to 140 °F (-30 to 60 °C); 1 month at 104 °F, 120 hours at 140 °F
Freezing	5 °F (-15 °C); ink thaws and is usable after at least 3 hours at 77 °F (25 °C)
<b>Capacity</b>	110 or 220 ml
<b>Weight</b>	
110 ml	Approximately 0.44 lb (200 g)
220 ml	Approximately 0.85 lb (385 g)

\* Preliminary data from Wilhelm Imaging Research, Inc. indicate the lightfastness of color UltraChrome™ prints made by the EPSON Stylus Pro 4000 printer will be rated up to 100 years under glass on specific EPSON media. Data indicate the lightfastness of black and white UltraChrome images will be rated as greater than 100 years under glass on specific EPSON media.

Ink lightfastness ratings are based on accelerated testing of prints on specialty media, displayed indoors, under glass. Actual print stability will vary according to media, printed image, display conditions, light intensity, humidity, and atmospheric conditions. EPSON does not guarantee longevity of prints. For maximum print life, display all prints under glass or lamination or properly store them. Visit [www.wilhelm-research.com](http://www.wilhelm-research.com) for the latest information.



# Index

## A

- Accessories, 10
- Aligning print head, 94 to 95
- Auto Cut setting
  - Mac OS 9, 61
  - Mac OS X, 53
  - Windows, 80
- Auto Rotate setting
  - Mac OS 9, 61
  - Windows, 80

## B

- Background printing, Mac OS 9, 68
- Banding, 116, 117
- Blank pages, 121
- Blurry prints, 118
- Borderless printing
  - Mac OS 9, 59 to 61
  - Mac OS X, 45
  - Windows, 77 to 79
- Buttons, control panel, 112

## C

- Cable
  - problems, 120, 121
  - requirements, 12
- Canceling print jobs
  - Mac OS 9, 69
  - Mac OS X, 55
  - Windows, 84
- Cartridges, *see* Ink cartridges
- Cleaner (cleaning unit), checking
  - status, 90 to 92
- Cleaning
  - print head, 92 to 94, 100
  - printer, 106
- Color management
  - Mac OS 9, 65
  - Mac OS X, 50 to 51
  - Windows, 82
- Color problems, 117, 121

- ColorSync settings, 51, 65
  - Component life, checking, 90 to 92
  - Configuration options
    - Mac OS 9, 70 to 71
    - Windows, 85 to 87
  - Control panel
    - aligning print head, 94 to 95
    - buttons, 112
    - changing language, 100
    - changing measurement units, 100
    - cleaning print head, 93 to 94
    - component life, checking, 90 to 92
    - illustration, 112
    - ink levels, checking, 90 to 92, 96
    - lights, 112 to 115
    - messages, 112 to 115
    - monitoring printer, 112 to 115
    - restoring default settings, 100
    - status check, printing, 90
  - CR (carriage) motor, checking status, 90 to 92
  - Custom paper size
    - Mac OS 9, 60
    - Mac OS X, 45 to 46
    - Windows, 79
  - Custom Preset, 54
  - Cut sheet paper
    - heavy stock, 35 to 40
    - loading, 20 to 25, 35 to 38
    - printable area, 134
    - tray capacity, 20
  - Cutter
    - cutting paper manually, 33
    - ordering replacement blade, 10
    - replacing blade, 101 to 103
    - service life, 131
- ## D
- Deleting print jobs
    - Mac OS 9, 69
    - Mac OS X, 55
    - Windows, 84
  - Diagnosing problems, 111

Dimensions of printer, 132  
Documentation, how to use, 9

## E

Electrical specifications, 132  
Energy consumption, 132  
ENERGY STAR, 13  
Engine reliability, 131  
Environmental specifications, 132

### EPSON

accessories, 10  
help, 11  
media, 18 to 19  
Preferred Protection Plan, 11  
Store, 10  
EpsonNet print server card, installing,  
129 to 130  
Error messages, 112 to 115  
Error notification  
Mac OS 9, 70 to 71  
Windows, 85 to 86  
Ethernet interface  
card, installing, 129 to 130  
card, ordering, 10  
system requirements, 12

## F

Faint prints, 118  
FireWire requirements, 12  
Flip Horizontal setting  
Mac OS 9, 65  
Mac OS X, 49  
problems, 121  
Windows, 81

## H

Head Alignment menu, 94  
Head unit (print head), checking  
status, 90 to 92  
Heavy media, cutting, 26  
Height of printer, 132  
Help, EPSON, 11

Hex dump, 100  
High Speed Copies setting  
Mac OS 9, 71  
Windows, 86  
High Speed setting  
Mac OS 9, 65  
Mac OS X, 49  
Windows, 81  
Humidity requirements, 132

## I

ICM setting, 82  
Ink  
lightfastness, 135  
maintenance tank, 90 to 92  
monitoring level, 56 to 57,  
69 to 70, 84 to 85, 90 to 92  
waste ink system, 131  
Ink cartridges  
checking status, 90 to 92, 96  
ordering, 97  
replacing, 96 to 99  
safety instructions, 15  
specifications, 135  
Ink light, 112 to 115

## J

Jams, paper, 123 to 128  
Job history, 91

## L

Layout  
Mac OS 9 options, 58 to 61  
Mac OS X options, 44 to 46  
Windows options, 76 to 80  
Lightfastness, 135  
Lights, control panel, 112 to 115

**M**

## Macintosh OS 9

- advanced print options, 64 to 67
- background printing, 68
- basic print options, 62 to 63
- borderless printing, 59 to 61
- canceling print jobs, 69
- checking ink levels, 69 to 70
- color management, 65
- configuration options, 70 to 71
- layout options, 58 to 61
- managing print jobs, 67 to 71
- Monitor IV, 68 to 69
- monitoring printer, 67 to 71
- network printing, 72
- page setup options, 58 to 61
- paper configuration options, 66 to 67
- roll paper options, 59 to 61
- sharing printer, 72
- software, uninstalling, 109
- Status Monitor, 69 to 70
- system requirements, 11 to 12
- Utility menu, 69 to 70

## Macintosh OS X

- basic print options, 47 to 50
- borderless printing, 45
- canceling print jobs, 55
- checking ink levels, 56 to 57
- color management, 50 to 51
- custom preset, 54
- layout options, 44 to 46
- monitoring print jobs, 55
- network printing, 57
- page setup options, 44 to 46
- paper configuration settings, 51 to 52
- Printer Utility, 56
- roll paper options, 53 to 54
- sharing printer, 57
- software, uninstalling, 109
- Status Monitor, 56 to 57
- system requirements, 11 to 12

Maintenance, 89 to 106

Maintenance menu, 94, 101

Maintenance mode, 100

Maintenance tank

- ordering, 10
- replacing, 104 to 105

Manuals, how to use, 9

Margins

- incorrect, 121
- minimum, 134
- printing without, 45, 59, 77 to 79

Mechanical specifications, 132

Media Type

- Mac OS 9, 62
- Mac OS X, 48
- Windows, 74 to 75

Memory

- problems, 120
- requirements, 11 to 12
- specifications, 131

MicroWeave setting, 65

Monitor IV, 68 to 69

Monitoring printer

- control panel, 112 to 115
- Mac OS 9, 67 to 71
- Mac OS X, 55, 56 to 57
- Windows, 84 to 86

Motors, checking status, 90 to 92

Moving printer, 106 to 108

**N**

Network card, installing, 129 to 130

Network printing

- Mac OS 9, 72
- Mac OS X, 57
- Windows, 87 to 88

**O**

Optional equipment, 10

**P**

- Page Line setting
  - control panel, 34
  - Mac OS 9, 61
  - Mac OS X, 54
  - Windows, 80
- Page setup options
  - Mac OS 9, 58 to 61
  - Mac OS X, 44 to 46
- Paper
  - attaching to spindle, 27
  - configuration settings, 51 to 52, 66 to 67, 82 to 84, 118
  - custom settings, 40 to 42
  - custom size, 45 to 46, 60, 79
  - cut sheet, 20 to 40
  - EPSON, 18 to 19
  - handling, 17 to 42
  - heavy stock, 35 to 40
  - jams, 123 to 128
  - loading in tray, 20 to 25
  - loading manually, 35 to 39
  - Mac OS 9 options, 58 to 61
  - Mac OS X options, 44 to 46
  - non-EPSON, 40 to 42
  - ordering, 18
  - printable area, 134
  - problems, 122 to 128
  - removing from spindle, 31
  - roll, 26 to 34
  - specifications, 133
  - suction, 41, 52, 66, 83
  - trim lines, 34, 54, 61, 80
  - Windows options, 76 to 80
- Paper cutter
  - replacing blade, 101 to 103
  - service life, 131
- Paper light, 112 to 115
- Paper Size setting
  - Mac OS 9, 60
  - Mac OS X, 45 to 46
  - problems, 121
  - Windows, 79
- Paper Source setting
  - Mac OS 9, 58, 60
  - Mac OS X, 45 to 46
  - problems, 121
  - Windows, 76, 78
- Paper tray
  - capacity, 20
  - loading, 20 to 25
- Pause light, 112 to 115
- Pausing print jobs
  - Mac OS 9, 69
  - Mac OS X, 55
  - Windows, 84
- PF (paper feed) motor, checking
  - status, 90 to 92
- PhotoEnhance, 65, 75, 82
- Platen gap setting, 118
- Posterboard, 35 to 40
- Power cleaning cycle, 93 to 94
- Power consumption, 132
- Print head
  - aligning, 94 to 95
  - checking status, 90 to 92
  - cleaning, 92 to 94, 100
  - locking, 108
  - service life, 131
- Print jobs
  - canceling, 55, 69, 84
  - managing, 67 to 71, 84 to 87
  - pausing, 55, 69, 84
- Print quality
  - Mac OS 9, 64
  - Mac OS X, 49
  - problems, 116 to 118
  - Windows, 81
- Print server, installing, 129 to 130
- Printer
  - checking status, 56 to 57, 69 to 71, 90 to 92
  - cleaning, 106
  - dimensions, 132
  - maintaining, 89 to 106
  - monitoring, 56 to 57, 67 to 71, 84 to 86, 115

## Printer (continued)

- motors, checking status, 90 to 92
- moving, 106 to 108
- port, 120
- software, uninstalling, 109 to 110
- specifications, 131 to 132
- stand, optional, 10
- status check, 90 to 92
- storing, 106 to 108
- total print volume, 91, 131
- transporting, 106 to 108
- turning off, 14
- weight, 132

## Problems

- banding, 116, 117
- blank paper, 121
- blurry prints, 118
- cable, 120, 121
- color, 117, 121
- diagnosing, 111
- faint prints, 118
- garbled characters, 121
- inverted image, 121
- margin, 121
- memory, 120
- misalignment, 116, 117
- nothing prints, 120
- operational, 119 to 120
- paper, 122 to 128
- paper feeding, 121
- paper jams, 123 to 128
- print quality, 116 to 118
- printer driver, 120 to 121
- printing stops, 120
- roll paper cannot be cut, 121
- smeared prints, 121

## Progress Meter, 84, 86

**R**

- RAM, *see* Memory
- Registering non-EPSON media, 40 to 42
- Requirements, system, 11 to 12

## Resolution

- Mac OS 9, 64
- Mac OS X, 49
- maximum, 131
- Windows, 81

## Roll paper

- attaching to spindle, 27
- cannot be cut, 121
- cutting manually, 33
- loading, 26 to 32
- Mac OS 9 settings, 59 to 61
- Mac OS X settings, 53 to 54
- Page Line setting, 54
- printable area, 134
- removing from spindle, 31
- Save Roll Paper setting, 54, 61, 80
- spacer, 32
- trim lines, 34, 54, 61, 80
- Windows settings, 78 to 80

**S**

## Safety

- approvals, 133
- instructions, 13 to 15

## Save Roll Paper setting, 54, 61, 80

## SelecType menus

- Custom Paper, 40 to 42
- Cutter Replace, 101
- Head Alignment, 94
- Maintenance, 94, 101
- Printer Status, 91
- Test Print, 90

## Software, uninstalling, 109 to 110

## Spacer, 32

## Specifications

- electrical, 132
- environmental, 132
- ink cartridges, 135
- mechanical, 132
- paper, 133
- printable area, 134
- printer, 131 to 132

## Speed and Progress utility, 85 to 87

- Spindle
  - adapter, 31
  - attaching spacer, 32
  - loading roll paper, 27
  - purchasing additional, 10
  - removing roll paper, 31
- Spool folders, Mac OS 9, 70 to 71
- sRGB setting, 82
- Stand, optional printer, 10
- Status Monitor
  - Mac OS 9, 69 to 70
  - Mac OS X, 56 to 57
  - Windows, 84 to 87
- Storing printer, 106 to 108
- Suction, 41, 52, 66, 83
- Support, EPSON, 11
- System requirements, 11 to 12

## T

- Technical support, 11
- Temperature requirements, 132
- Test Print menu, 90
- Total prints, checking, 91
- Transporting printer, 106 to 108
- Trim lines, printing
  - control panel, 34
  - Mac OS 9, 61
  - Mac OS X, 54
  - Windows, 80
- Troubleshooting, 111 to 128

## U

- UltraChrome ink cartridges, 97
- Ultrasonic cleaning cycle, 100
- Uninstalling software, 109 to 110
- Unit ID number, 11
- Usage count, 91

- USB
  - cable requirements, 12
  - driver, uninstalling, 110
- User-defined paper size, 79
- Utility menu
  - Mac OS 9, 69 to 70
  - Mac OS X, 56
  - Windows, 83

## W

- Waste ink system, 90 to 92,  
104 to 105, 131
- Weight of printer, 132
- Width of printer, 132
- Windows
  - advanced print options, 80 to 84
  - basic print options, 74 to 76
  - canceling print jobs, 84
  - checking ink levels, 84
  - color management, 82
  - driver, 73 to 84
  - layout options, 76 to 80
  - managing print jobs, 84 to 87
  - monitoring preferences, setting,  
85 to 87
  - network printing, 87 to 88
  - optimizing print speed, 85 to 87
  - paper configuration options,  
82 to 84
  - roll paper options, 78 to 80
  - sharing printer, 87 to 88
  - software, uninstalling, 109
  - Speed and Progress utility, 85 to 87
  - status alerts, 86
  - Status Monitor, 84 to 87
  - system requirements, 12
  - user-defined paper size, 79

# Control Panel Lights and Buttons

